

NETWORK THEOREMS

9

OBJECTIVES

- *Become familiar with the superposition theorem and its unique ability to separate the impact of each source on the quantity of interest.*
- *Be able to apply Thévenin's theorem to reduce any two-terminal, series-parallel network with any number of sources to a single voltage source and series resistor.*
- *Become familiar with Norton's theorem and how it can be used to reduce any two-terminal, series-parallel network with any number of sources to a single current source and a parallel resistor.*
- *Understand how to apply the maximum power transfer theorem to determine the maximum power to a load and to choose a load that will receive maximum power.*
- *Become aware of the reduction powers of Millman's theorem and the powerful implications of the substitution and reciprocity theorems.*

9.1 INTRODUCTION

This chapter introduces a number of theorems that have application throughout the field of electricity and electronics. Not only can they be used to solve networks such as encountered in the previous chapter, but they also provide an opportunity to determine the impact of a particular source or element on the response of the entire system. In most cases, the network to be analyzed and the mathematics required to find the solution are simplified. All of the theorems appear again in the analysis of ac networks. In fact, the application of each theorem to ac networks is very similar in content to that found in this chapter.

The first theorem to be introduced is the superposition theorem, followed by Thévenin's theorem, Norton's theorem, and the maximum power transfer theorem. The chapter concludes with a brief introduction to Millman's theorem and the substitution and reciprocity theorems.

9.2 SUPERPOSITION THEOREM

The **superposition theorem** is unquestionably one of the most powerful in this field. It has such widespread application that people often apply it without recognizing that their maneuvers are valid only because of this theorem.

In general, the theorem can be used to do the following:

- *Analyze networks such as introduced in the last chapter that have two or more sources that are not in series or parallel.*
- *Reveal the effect of each source on a particular quantity of interest.*
- *For sources of different types (such as dc and ac, which affect the parameters of the network in a different manner) and apply a separate analysis for each type, with the total result simply the algebraic sum of the results.*

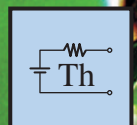



The first two areas of application are described in detail in this section. The last are covered in the discussion of the superposition theorem in the ac portion of the text.

The superposition theorem states the following:

The current through, or voltage across, any element of a network is equal to the algebraic sum of the currents or voltages produced independently by each source.

In other words, this theorem allows us to find a solution for a current or voltage using *only one source at a time*. Once we have the solution for each source, we can combine the results to obtain the total solution. The term *algebraic* appears in the above theorem statement because the currents resulting from the sources of the network can have different directions, just as the resulting voltages can have opposite polarities.

If we are to consider the effects of each source, the other sources obviously must be removed. Setting a voltage source to zero volts is like placing a short circuit across its terminals. Therefore,

when removing a voltage source from a network schematic, replace it with a direct connection (short circuit) of zero ohms. Any internal resistance associated with the source must remain in the network.

Setting a current source to zero amperes is like replacing it with an open circuit. Therefore,

when removing a current source from a network schematic, replace it by an open circuit of infinite ohms. Any internal resistance associated with the source must remain in the network.

The above statements are illustrated in Fig. 9.1.

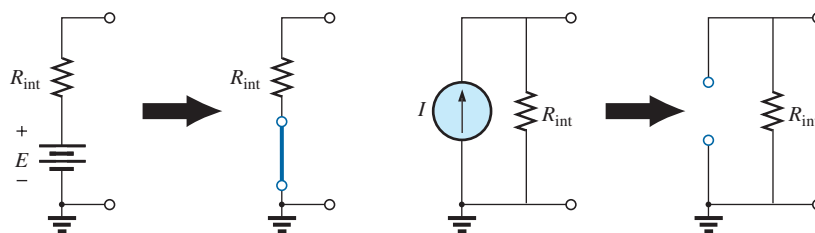

FIG. 9.1

Removing a voltage source and a current source to permit the application of the superposition theorem.

Since the effect of each source will be determined independently, the number of networks to be analyzed will equal the number of sources.

If a particular current of a network is to be determined, the contribution to that current must be determined for *each source*. When the effect of each source has been determined, those currents in the same direction are added, and those having the opposite direction are subtracted; the algebraic sum is being determined. The total result is the direction of the larger sum and the magnitude of the difference.

Similarly, if a particular voltage of a network is to be determined, the contribution to that voltage must be determined for each source. When the effect of each source has been determined, those voltages with the same polarity are added, and those with the opposite polarity are subtracted; the algebraic sum is being determined. The total result has the polarity of the larger sum and the magnitude of the difference.

Superposition cannot be applied to power effects because the power is related to the square of the voltage across a resistor or the current through a resistor. The squared term results in a nonlinear (a curve, not a straight line) relationship between the power and the determining current or voltage. For example, doubling the current through a resistor does not double the power to the resistor (as defined by a linear relationship) but, in fact, increases it by a factor of 4 (due to the squared term). Tripling the current increases the power level by a factor of 9. Example 9.1 demonstrates the differences between a linear and a nonlinear relationship.

A few examples clarify how sources are removed and total solutions obtained.

EXAMPLE 9.1

- Using the superposition theorem, determine the current through resistor R_2 for the network in Fig. 9.2.
- Demonstrate that the superposition theorem is not applicable to power levels.

Solutions:

- In order to determine the effect of the 36 V voltage source, the current source must be replaced by an open-circuit equivalent as shown in Fig. 9.3. The result is a simple series circuit with a current equal to

$$I'_2 = \frac{E}{R_T} = \frac{E}{R_1 + R_2} = \frac{36 \text{ V}}{12 \Omega + 6 \Omega} = \frac{36 \text{ V}}{18 \Omega} = 2 \text{ A}$$

Examining the effect of the 9 A current source requires replacing the 36 V voltage source by a short-circuit equivalent as shown in Fig. 9.4. The result is a parallel combination of resistors R_1 and R_2 . Applying the current divider rule results in

$$I''_2 = \frac{R_1(I)}{R_1 + R_2} = \frac{(12 \Omega)(9 \text{ A})}{12 \Omega + 6 \Omega} = 6 \text{ A}$$

Since the contribution to current I_2 has the same direction for each source, as shown in Fig. 9.5, the total solution for current I_2 is the sum of the currents established by the two sources. That is,

$$I_2 = I'_2 + I''_2 = 2 \text{ A} + 6 \text{ A} = 8 \text{ A}$$

- Using Fig. 9.3 and the results obtained, we find the power delivered to the 6 Ω resistor

$$P_1 = (I'_2)^2(R_2) = (2 \text{ A})^2(6 \Omega) = 24 \text{ W}$$

Using Fig. 9.4 and the results obtained, we find the power delivered to the 6 Ω resistor

$$P_2 = (I''_2)^2(R_2) = (6 \text{ A})^2(6 \Omega) = 216 \text{ W}$$

Using the total results of Fig. 9.5, we obtain the power delivered to the 6 Ω resistor

$$P_T = I_2^2 R_2 = (8 \text{ A})^2(6 \Omega) = 384 \text{ W}$$

It is now quite clear that the power delivered to the 6 Ω resistor using the total current of 8 A is not equal to the sum of the power levels due to each source independently. That is,

$$P_1 + P_2 = 24 \text{ W} + 216 \text{ W} = 240 \text{ W} \neq P_T = 384 \text{ W}$$

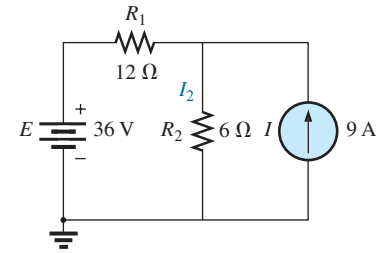

FIG. 9.2

Network to be analyzed in Example 9.1 using the superposition theorem.

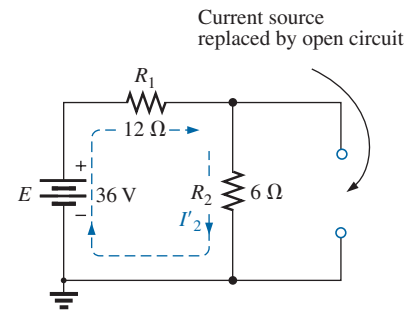

FIG. 9.3

Replacing the 9 A current source in Fig. 9.2 by an open circuit to determine the effect of the 36 V voltage source on current I_2 .

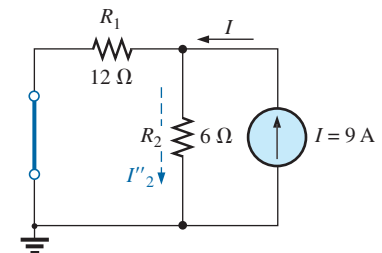

FIG. 9.4

Replacing the 36 V voltage source by a short-circuit equivalent to determine the effect of the 9 A current source on current I_2 .

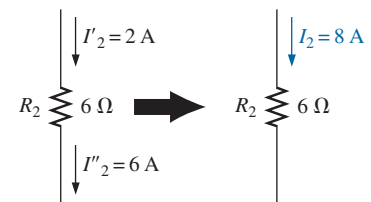

FIG. 9.5

Using the results of Figs. 9.3 and 9.4 to determine current I_2 for the network in Fig. 9.2.



To expand on the above conclusion and further demonstrate what is meant by a *nonlinear relationship*, the power to the $6\ \Omega$ resistor versus current through the $6\ \Omega$ resistor is plotted in Fig. 9.6. Note that the curve is not a straight line but one whose rise gets steeper with increase in current level.

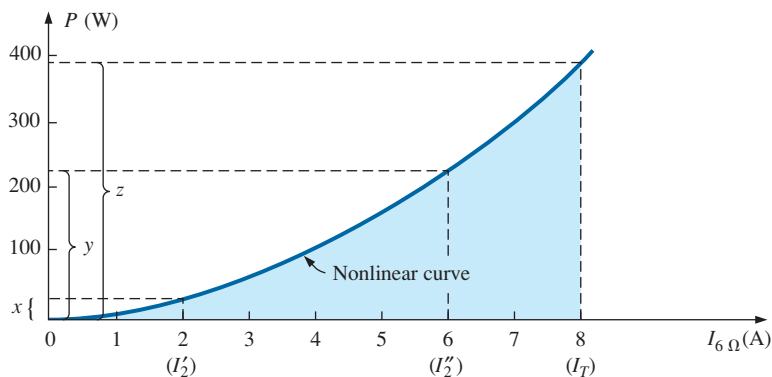

FIG. 9.6

Plotting power delivered to the $6\ \Omega$ resistor versus current through the resistor.

Recall from Fig. 9.3 that the power level was $24\ \text{W}$ for a current of $2\ \text{A}$ developed by the $36\ \text{V}$ voltage source, shown in Fig. 9.6. From Fig. 9.4, we found that the current level was $6\ \text{A}$ for a power level of $216\ \text{W}$, shown in Fig. 9.6. Using the total current of $8\ \text{A}$, we find that the power level is $384\ \text{W}$, shown in Fig. 9.6. Quite clearly, the sum of power levels due to the $2\ \text{A}$ and $6\ \text{A}$ current levels does not equal that due to the $8\ \text{A}$ level. That is,

$$x + y \neq z$$

Now, the relationship between the voltage across a resistor and the current through a resistor is a linear (straight line) one, as shown in Fig. 9.7, with

$$c = a + b$$

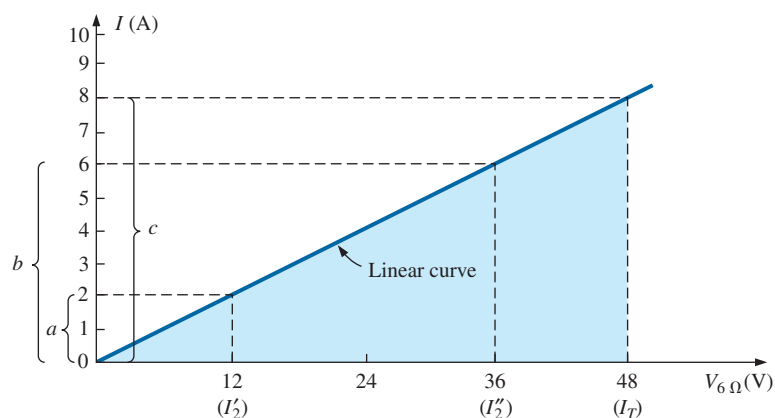

FIG. 9.7

Plotting I versus V for the $6\ \Omega$ resistor.

EXAMPLE 9.2 Using the superposition theorem, determine the current through the $12\ \Omega$ resistor in Fig. 9.8. Note that this is a two-source network of the type examined in the previous chapter when we applied branch-current analysis and mesh analysis.

Solution: Considering the effects of the $54\ \text{V}$ source requires replacing the $48\ \text{V}$ source by a short-circuit equivalent as shown in Fig. 9.9. The result is that the $12\ \Omega$ and $4\ \Omega$ resistors are in parallel.

The total resistance seen by the source is therefore

$$R_T = R_1 + R_2 \parallel R_3 = 24\ \Omega + 12\ \Omega \parallel 4\ \Omega = 24\ \Omega + 3\ \Omega = 27\ \Omega$$

and the source current is

$$I_s = \frac{E_1}{R_T} = \frac{54\ \text{V}}{27\ \Omega} = 2\ \text{A}$$

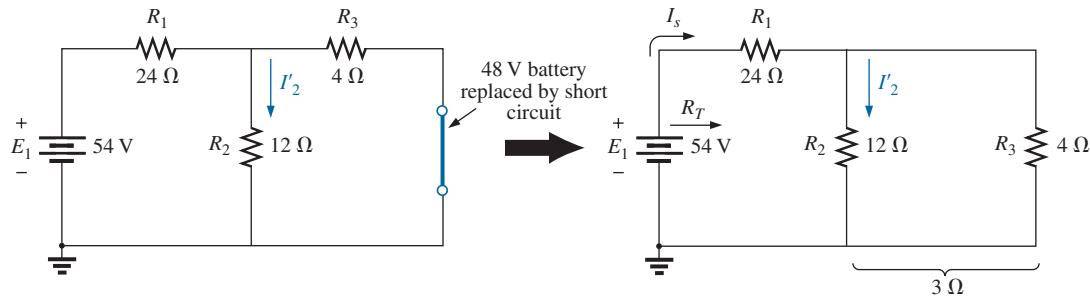

FIG. 9.9

Using the superposition theorem to determine the effect of the $54\ \text{V}$ voltage source on current I_2 in Fig. 9.8.

Using the current divider rule results in the contribution to I_2 due to the $54\ \text{V}$ source:

$$I'_2 = \frac{R_3 I_s}{R_3 + R_2} = \frac{(4\ \Omega)(2\ \text{A})}{4\ \Omega + 12\ \Omega} = 0.5\ \text{A}$$

If we now replace the $54\ \text{V}$ source by a short-circuit equivalent, the network in Fig. 9.10 results. The result is a parallel connection for the $12\ \Omega$ and $24\ \Omega$ resistors.

Therefore, the total resistance seen by the $48\ \text{V}$ source is

$$R_T = R_3 + R_2 \parallel R_1 = 4\ \Omega + 12\ \Omega \parallel 24\ \Omega = 4\ \Omega + 8\ \Omega = 12\ \Omega$$

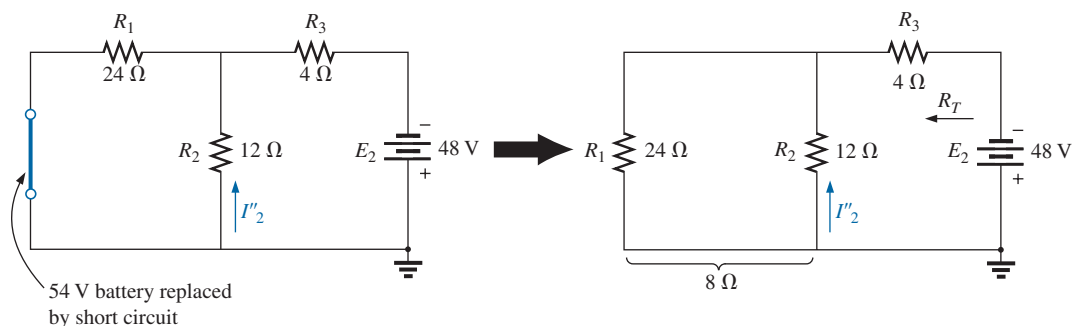

FIG. 9.10

Using the superposition theorem to determine the effect of the $48\ \text{V}$ voltage source on current I_2 in Fig. 9.8.

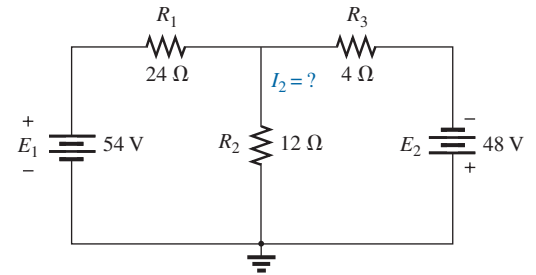

FIG. 9.8

Using the superposition theorem to determine the current through the $12\ \Omega$ resistor (Example 9.2).

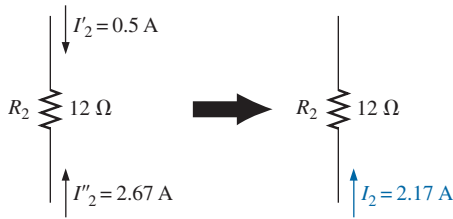

FIG. 9.11

Using the results of Figs. 9.9 and 9.10 to determine current I_2 for the network in Fig. 9.8.

and the source current is

$$I_s = \frac{E_2}{R_T} = \frac{48 \text{ V}}{12 \Omega} = 4 \text{ A}$$

Applying the current divider rule results in

$$I'_2 = \frac{R_1(I_s)}{R_1 + R_2} = \frac{(24 \Omega)(4 \text{ A})}{24 \Omega + 12 \Omega} = 2.67 \text{ A}$$

It is now important to realize that current I_2 due to each source has a different direction, as shown in Fig. 9.11. The net current therefore is the difference of the two and in the direction of the larger as follows:

$$I_2 = I'_2 - I'_2 = 2.67 \text{ A} - 0.5 \text{ A} = \mathbf{2.17 \text{ A}}$$

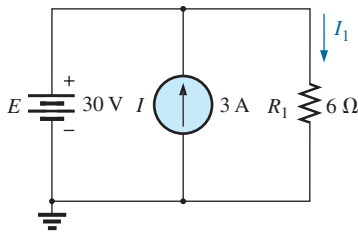

FIG. 9.12

Two-source network to be analyzed using the superposition theorem in Example 9.3.

Using Figs. 9.9 and 9.10 in Example 9.2, we can determine the other currents of the network with little added effort. That is, we can determine all the branch currents of the network, matching an application of the branch-current analysis or mesh analysis approach. In general, therefore, not only can the superposition theorem provide a complete solution for the network, but it also reveals the effect of each source on the desired quantity.

EXAMPLE 9.3 Using the superposition theorem, determine current I_1 for the network in Fig. 9.12.

Solution: Since two sources are present, there are two networks to be analyzed. First let us determine the effects of the voltage source by setting the current source to zero amperes as shown in Fig. 9.13. Note that the resulting current is defined as I'_1 because it is the current through resistor R_1 due to the voltage source only.

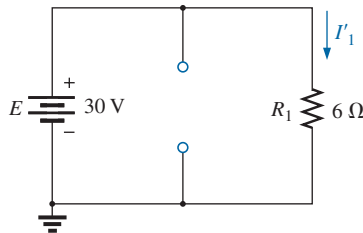

FIG. 9.13

Determining the effect of the 30 V supply on the current I_1 in Fig. 9.12.

Due to the open circuit, resistor R_1 is in series (and, in fact, in parallel) with the voltage source E . The voltage across the resistor is the applied voltage, and current I'_1 is determined by

$$I'_1 = \frac{V_1}{R_1} = \frac{E}{R_1} = \frac{30 \text{ V}}{6 \Omega} = 5 \text{ A}$$

Now for the contribution due to the current source. Setting the voltage source to zero volts results in the network in Fig. 9.14, which presents us with an interesting situation. The current source has been replaced with a short-circuit equivalent that is directly across the current source and resistor R_1 . Since the source current takes the path of least resistance, it chooses the zero ohm path of the inserted short-circuit equivalent, and the current through R_1 is zero amperes. This is clearly demonstrated by an application of the current divider rule as follows:

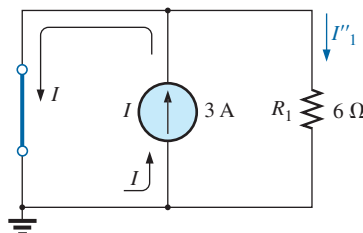

FIG. 9.14

Determining the effect of the 3 A current source on the current I_1 in Fig. 9.12.

$$I''_1 = \frac{R_{sc}I}{R_{sc} + R_1} = \frac{(0 \Omega)I}{0 \Omega + 6 \Omega} = 0 \text{ A}$$

Since I'_1 and I''_1 have the same defined direction in Figs. 9.13 and 9.14, the total current is defined by

$$I_1 = I'_1 + I''_1 = 5 \text{ A} + 0 \text{ A} = \mathbf{5 \text{ A}}$$

Although this has been an excellent introduction to the application of the superposition theorem, it should be immediately clear in Fig. 9.12 that the voltage source is in parallel with the current source and load



resistor R_1 , so the voltage across each must be 30 V. The result is that I_1 must be determined solely by

$$I_1 = \frac{V_1}{R_1} = \frac{E}{R_1} = \frac{30 \text{ V}}{6 \Omega} = 5 \text{ A}$$

EXAMPLE 9.4 Using the principle of superposition, find the current I_2 through the 12 k Ω resistor in Fig. 9.15.

Solution: Consider the effect of the 6 mA current source (Fig. 9.16).

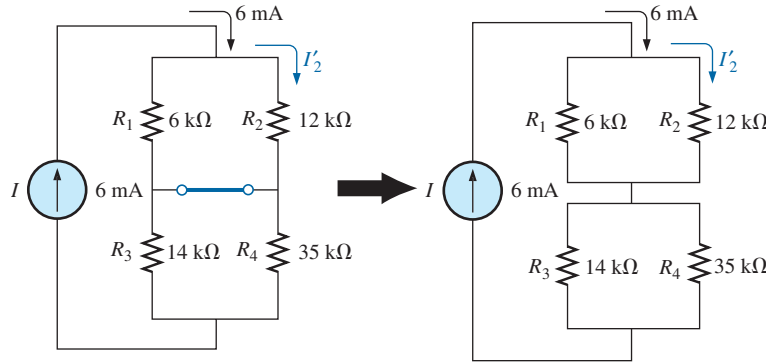

FIG. 9.16

The effect of the current source I on the current I_2 .

The current divider rule gives

$$I_2' = \frac{R_1 I}{R_1 + R_2} = \frac{(6 \text{ k}\Omega)(6 \text{ mA})}{6 \text{ k}\Omega + 12 \text{ k}\Omega} = 2 \text{ mA}$$

Considering the effect of the 9 V voltage source (Fig. 9.17) gives

$$I_2'' = \frac{E}{R_1 + R_2} = \frac{9 \text{ V}}{6 \text{ k}\Omega + 12 \text{ k}\Omega} = 0.5 \text{ mA}$$

Since I_2' and I_2'' have the same direction through R_2 , the desired current is the sum of the two:

$$\begin{aligned} I_2 &= I_2' + I_2'' \\ &= 2 \text{ mA} + 0.5 \text{ mA} \\ &= \mathbf{2.5 \text{ mA}} \end{aligned}$$

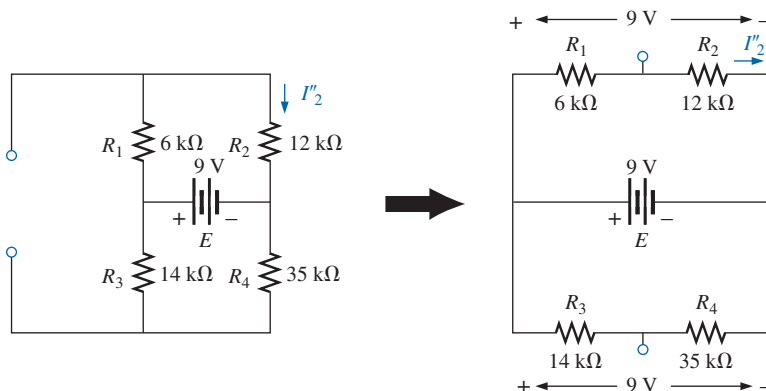

FIG. 9.17

The effect of the voltage source E on the current I_2 .

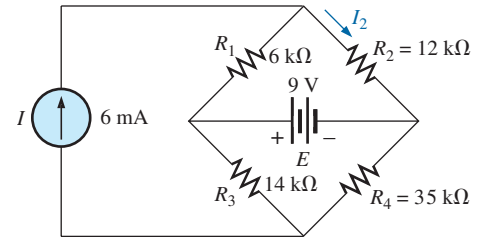

FIG. 9.15
Example 9.4.

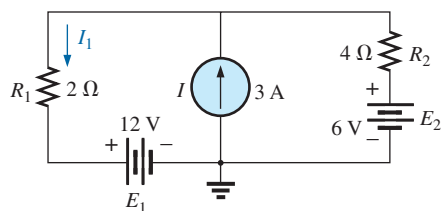

FIG. 9.18
Example 9.5.

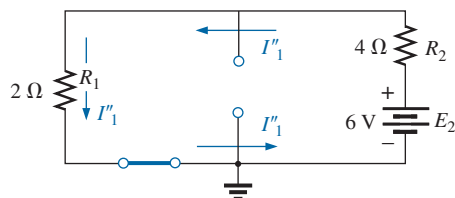

FIG. 9.20
The effect of E_2 on the current I_1 .

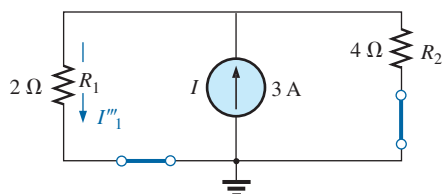

FIG. 9.21
The effect of I on the current I_1 .

EXAMPLE 9.5 Find the current through the $2\ \Omega$ resistor of the network in Fig. 9.18. The presence of three sources results in three different networks to be analyzed.

Solution: Consider the effect of the 12 V source (Fig. 9.19):

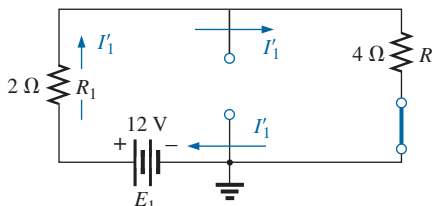

FIG. 9.19

The effect of E_1 on the current I_1 .

$$I'_1 = \frac{E_1}{R_1 + R_2} = \frac{12\ \text{V}}{2\ \Omega + 4\ \Omega} = \frac{12\ \text{V}}{6\ \Omega} = 2\ \text{A}$$

Consider the effect of the 6 V source (Fig. 9.20):

$$I''_1 = \frac{E_2}{R_1 + R_2} = \frac{6\ \text{V}}{2\ \Omega + 4\ \Omega} = \frac{6\ \text{V}}{6\ \Omega} = 1\ \text{A}$$

Consider the effect of the 3 A source (Fig. 9.21): Applying the current divider rule gives

$$I'''_1 = \frac{R_2 I}{R_1 + R_2} = \frac{(4\ \Omega)(3\ \text{A})}{2\ \Omega + 4\ \Omega} = \frac{12\ \text{A}}{6} = 2\ \text{A}$$

The total current through the $2\ \Omega$ resistor appears in Fig. 9.22, and

$$I_1 = \overbrace{I''_1 + I'''_1}^{\text{Same direction as } I_1 \text{ in Fig. 9.18}} - \overbrace{I'_1}^{\text{Opposite direction to } I_1 \text{ in Fig. 9.18}}$$

$$= 1\ \text{A} + 2\ \text{A} - 2\ \text{A} = 1\ \text{A}$$

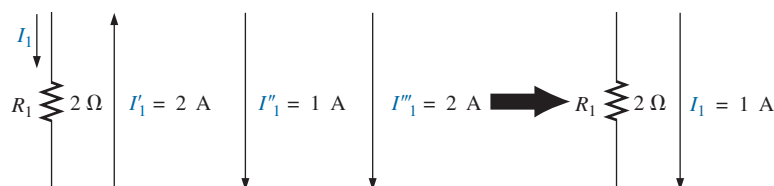

FIG. 9.22

The resultant current I_1 .

9.3 THÉVENIN'S THEOREM

The next theorem to be introduced, **Thévenin's theorem**, is probably one of the most interesting in that it permits the reduction of complex networks to a simpler form for analysis and design.

In general, the theorem can be used to do the following:

- Analyze networks with sources that are not in series or parallel.
- Reduce the number of components required to establish the same characteristics at the output terminals.



- Investigate the effect of changing a particular component on the behavior of a network without having to analyze the entire network after each change.

All three areas of application are demonstrated in the examples to follow. Thévenin's theorem states the following:

Any two-terminal dc network can be replaced by an equivalent circuit consisting solely of a voltage source and a series resistor as shown in Fig. 9.23.

The theorem was developed by Commandant Leon-Charles Thévenin in 1883 as described in Fig. 9.24.

To demonstrate the power of the theorem, consider the fairly complex network of Fig. 9.25(a) with its two sources and series-parallel connections. The theorem states that the entire network inside the blue shaded area can be replaced by one voltage source and one resistor as shown in Fig. 9.25(b). If the replacement is done properly, the voltage across, and the current through, the resistor R_L will be the same for each network. The value of R_L can be changed to any value, and the voltage, current, or power to the load resistor is the same for each configuration. Now, this is a very powerful statement—one that is verified in the examples to follow.

The question then is, How can you determine the proper value of Thévenin voltage and resistance? In general, finding the Thévenin *resistance* value is quite straightforward. Finding the Thévenin *voltage* can be more of a challenge and, in fact, may require using the superposition theorem or one of the methods described in Chapter 8.

Fortunately, there is a series of steps that will lead to the proper value of each parameter. Although a few of the steps may seem trivial at first, they can become quite important when the network becomes complex.

Thévenin's Theorem Procedure

Preliminary:

1. Remove that portion of the network where the Thévenin equivalent circuit is found. In Fig. 9.25(a), this requires that the load resistor R_L be temporarily removed from the network.
2. Mark the terminals of the remaining two-terminal network. (The importance of this step will become obvious as we progress through some complex networks.)

R_{Th} :

3. Calculate R_{Th} by first setting all sources to zero (voltage sources are replaced by short circuits and current sources by open circuits) and then finding the resultant resistance between the two marked terminals. (If the internal resistance of the voltage and/or current sources is included in the original network, it must remain when the sources are set to zero.)

E_{Th} :

4. Calculate E_{Th} by first returning all sources to their original position and finding the open-circuit voltage between the marked terminals. (This step is invariably the one that causes most confusion and errors. In all cases, keep in mind that it is the open-circuit potential between the two terminals marked in step 2.)

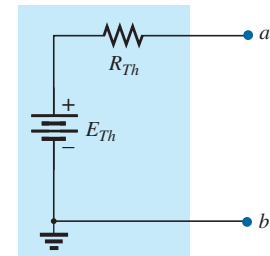

FIG. 9.23

Thévenin equivalent circuit.



FIG. 9.24

Leon-Charles Thévenin.
Courtesy of the Bibliothèque École Polytechnique, Paris, France.

French (Meaux, Paris)
(1857–1927)

Telegraph Engineer, Commandant and Educator
École Polytechnique and École Supérieure de
Télégraphie

Although active in the study and design of telegraphic systems (including underground transmission), cylindrical condensers (capacitors), and electromagnetism, he is best known for a theorem first presented in the French *Journal of Physics—Theory and Applications* in 1883. It appeared under the heading of “Sur un nouveau théorème d'électricité dynamique” (“On a new theorem of dynamic electricity”) and was originally referred to as the *equivalent generator theorem*. There is some evidence that a similar theorem was introduced by Hermann von Helmholtz in 1853. However, Professor Helmholtz applied the theorem to animal physiology and not to communication or generator systems, and therefore he has not received the credit in this field that he might deserve. In the early 1920s AT&T did some pioneering work using the equivalent circuit and may have initiated the reference to the theorem as simply Thévenin's theorem. In fact, Edward L. Norton, an engineer at AT&T at the time, introduced a current source equivalent of the Thévenin equivalent currently referred to as the Norton equivalent circuit. As an aside, Commandant Thévenin was an avid skier and in fact was commissioner of an international ski competition in Chamonix, France, in 1912.



Conclusion:

5. Draw the Thévenin equivalent circuit with the portion of the circuit previously removed replaced between the terminals of the equivalent circuit. This step is indicated by the placement of the resistor R_L between the terminals of the Thévenin equivalent circuit as shown in Fig. 9.25(b).

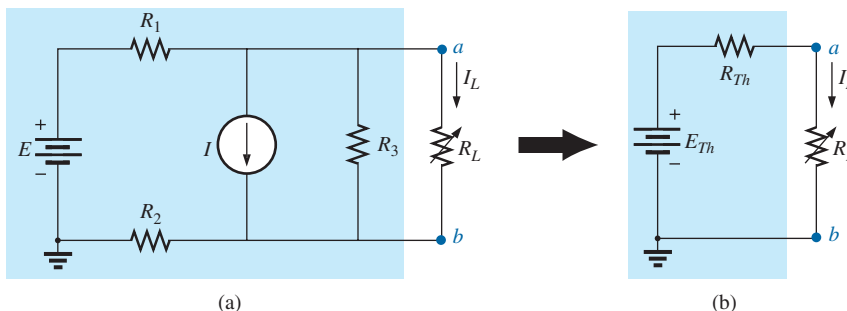

FIG. 9.25

Substituting the Thévenin equivalent circuit for a complex network.

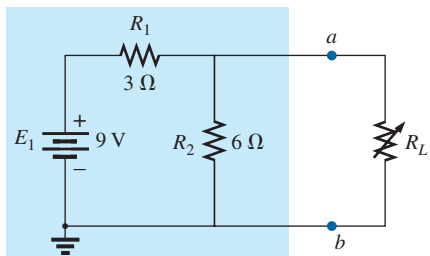

FIG. 9.26

Example 9.6.

EXAMPLE 9.6 Find the Thévenin equivalent circuit for the network in the shaded area of the network in Fig. 9.26. Then find the current through R_L for values of $2\ \Omega$, $10\ \Omega$, and $100\ \Omega$.

Solution:

Steps 1 and 2: These produce the network in Fig. 9.27. Note that the load resistor R_L has been removed and the two “holding” terminals have been defined as a and b .

Step 3: Replacing the voltage source E_1 with a short-circuit equivalent yields the network in Fig. 9.28(a), where

$$R_{Th} = R_1 \parallel R_2 = \frac{(3\ \Omega)(6\ \Omega)}{3\ \Omega + 6\ \Omega} = 2\ \Omega$$

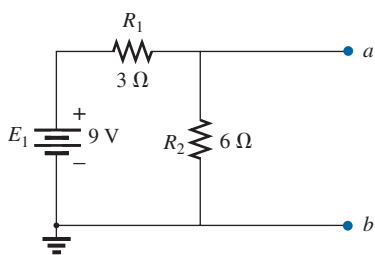

FIG. 9.27

Identifying the terminals of particular importance when applying Thévenin’s theorem.

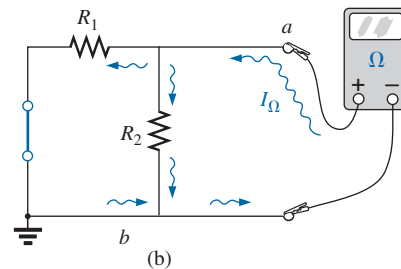
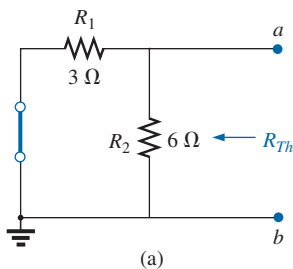

FIG. 9.28

Determining R_{Th} for the network in Fig. 9.27.

The importance of the two marked terminals now begins to surface. They are the two terminals across which the Thévenin resistance is measured. It is no longer the total resistance as seen by the source, as determined in the majority of problems of Chapter 7. If some difficulty develops when determining R_{Th} with regard to whether the resistive elements are in series or parallel, consider recalling that the ohmmeter sends out a trickle current into a resistive combination and senses the



level of the resulting voltage to establish the measured resistance level. In Fig. 9.28(b), the trickle current of the ohmmeter approaches the network through terminal a , and when it reaches the junction of R_1 and R_2 , it splits as shown. The fact that the trickle current splits and then recombines at the lower node reveals that the resistors are in parallel as far as the ohmmeter reading is concerned. In essence, the path of the sensing current of the ohmmeter has revealed how the resistors are connected to the two terminals of interest and how the Thévenin resistance should be determined. Remember this as you work through the various examples in this section.

Step 4: Replace the voltage source (Fig. 9.29). For this case, the open-circuit voltage E_{Th} is the same as the voltage drop across the $6\ \Omega$ resistor. Applying the voltage divider rule gives

$$E_{Th} = \frac{R_2 E_1}{R_2 + R_1} = \frac{(6\ \Omega)(9\ \text{V})}{6\ \Omega + 3\ \Omega} = \frac{54\ \text{V}}{9} = 6\ \text{V}$$

It is particularly important to recognize that E_{Th} is the open-circuit potential between points a and b . Remember that an open circuit can have any voltage across it, but the current must be zero. In fact, the current through any element in series with the open circuit must be zero also. The use of a voltmeter to measure E_{Th} appears in Fig. 9.30. Note that it is placed directly across the resistor R_2 since E_{Th} and V_{R_2} are in parallel.

Step 5: (Fig. 9.31):

$$I_L = \frac{E_{Th}}{R_{Th} + R_L}$$

$$R_L = 2\ \Omega: \quad I_L = \frac{6\ \text{V}}{2\ \Omega + 2\ \Omega} = 1.5\ \text{A}$$

$$R_L = 10\ \Omega: \quad I_L = \frac{6\ \text{V}}{2\ \Omega + 10\ \Omega} = 0.5\ \text{A}$$

$$R_L = 100\ \Omega: \quad I_L = \frac{6\ \text{V}}{2\ \Omega + 100\ \Omega} = 0.06\ \text{A}$$

If Thévenin's theorem were unavailable, each change in R_L would require that the entire network in Fig. 9.26 be reexamined to find the new value of R_L .

EXAMPLE 9.7 Find the Thévenin equivalent circuit for the network in the shaded area of the network in Fig. 9.32.

Solution:

Steps 1 and 2: See Fig. 9.33.

Step 3: See Fig. 9.34. The current source has been replaced with an open-circuit equivalent and the resistance determined between terminals a and b .

In this case, an ohmmeter connected between terminals a and b sends out a sensing current that flows directly through R_1 and R_2 (at the same level). The result is that R_1 and R_2 are in series and the Thévenin resistance is the sum of the two,

$$R_{Th} = R_1 + R_2 = 4\ \Omega + 2\ \Omega = 6\ \Omega$$

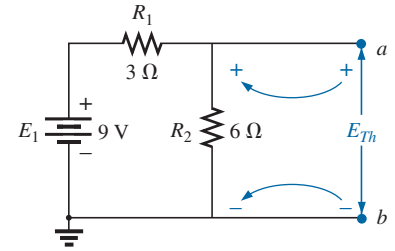

FIG. 9.29

Determining E_{Th} for the network in Fig. 9.27.

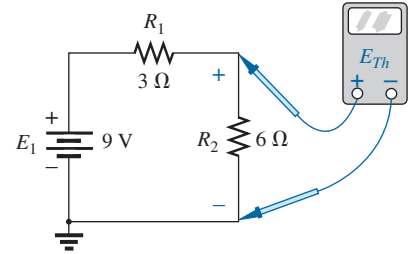

FIG. 9.30

Measuring E_{Th} for the network in Fig. 9.27.

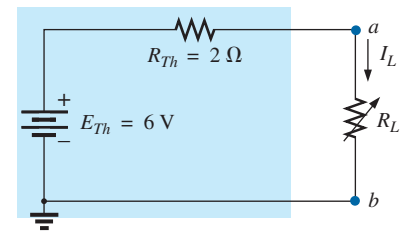

FIG. 9.31

Substituting the Thévenin equivalent circuit for the network external to R_L in Fig. 9.26.

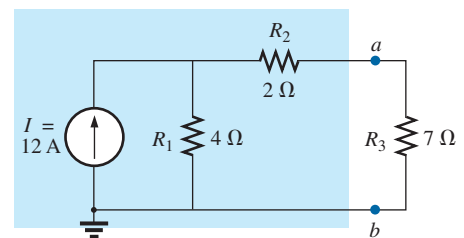

FIG. 9.32

Example 9.7.

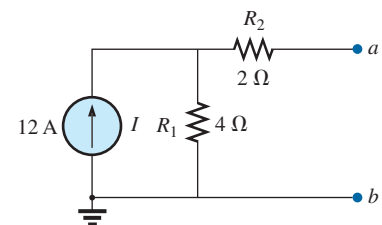

FIG. 9.33

Establishing the terminals of particular interest for the network in Fig. 9.32.

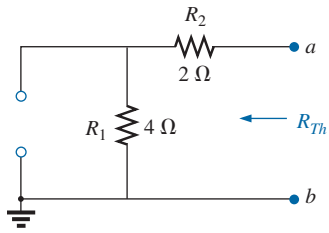

FIG. 9.34

Determining R_{Th} for the network in Fig. 9.33.

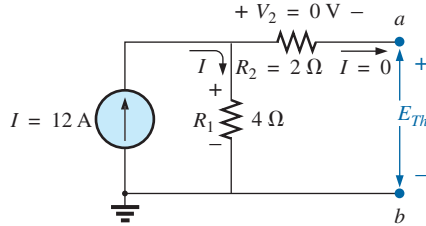

FIG. 9.35

Determining E_{Th} for the network in Fig. 9.33.

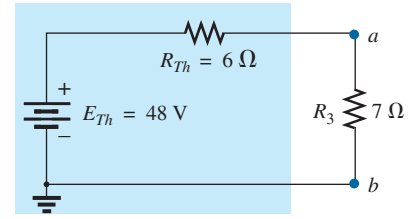

FIG. 9.36

Substituting the Thévenin equivalent circuit in the network external to the resistor R_3 in Fig. 9.32.

Step 4: See Fig. 9.35. In this case, since an open circuit exists between the two marked terminals, the current is zero between these terminals and through the $2\ \Omega$ resistor. The voltage drop across R_2 is, therefore,

$$V_2 = I_2 R_2 = (0) R_2 = 0\text{ V}$$

and $E_{Th} = V_1 = I_1 R_1 = IR_1 = (12\text{ A})(4\ \Omega) = 48\text{ V}$

Step 5: See Fig. 9.36.

EXAMPLE 9.8 Find the Thévenin equivalent circuit for the network in the shaded area of the network in Fig. 9.37. Note in this example that there is no need for the section of the network to be preserved to be at the “end” of the configuration.

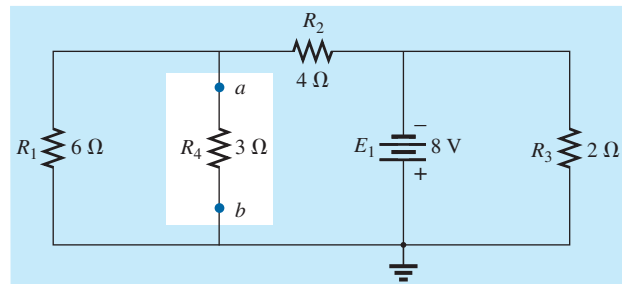

FIG. 9.37

Example 9.8.

Solution:

Steps 1 and 2: See Fig. 9.38.

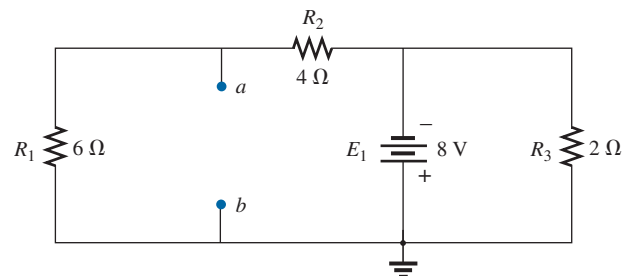
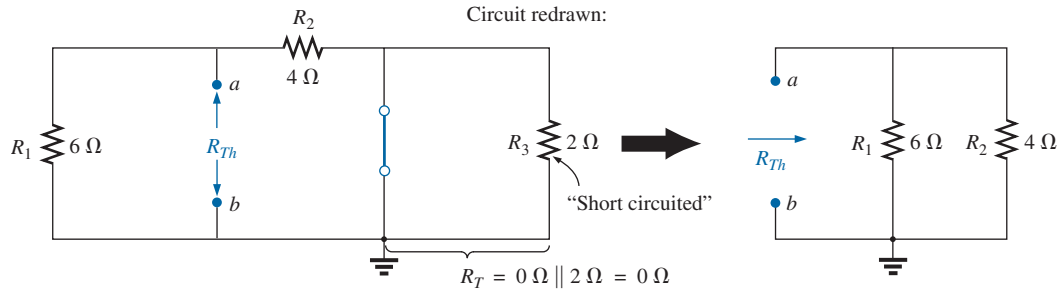

FIG. 9.38

Identifying the terminals of particular interest for the network in Fig. 9.37.

FIG. 9.39

Determining R_{Th} for the network in Fig. 9.38.

Step 3: See Fig. 9.39. Steps 1 and 2 are relatively easy to apply, but now we must be careful to “hold” onto the terminals a and b as the Thévenin resistance and voltage are determined. In Fig. 9.39, all the remaining elements turn out to be in parallel, and the network can be redrawn as shown. We have

$$R_{Th} = R_1 \parallel R_2 = \frac{(6 \Omega)(4 \Omega)}{6 \Omega + 4 \Omega} = \frac{24 \Omega}{10} = \mathbf{2.4 \Omega}$$

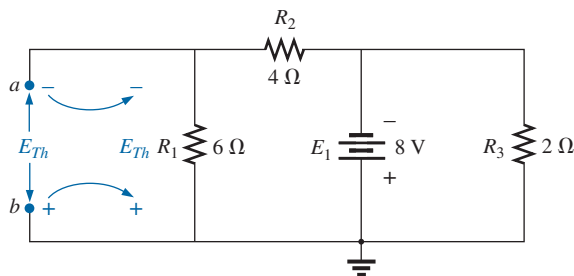
FIG. 9.40

Determining E_{Th} for the network in Fig. 9.38.

Step 4: See Fig. 9.40. In this case, the network can be redrawn as shown in Fig. 9.41. Since the voltage is the same across parallel elements, the voltage across the series resistors R_1 and R_2 is E_1 , or 8 V. Applying the voltage divider rule gives

$$E_{Th} = \frac{R_1 E_1}{R_1 + R_2} = \frac{(6 \Omega)(8 \text{ V})}{6 \Omega + 4 \Omega} = \frac{48 \text{ V}}{10} = \mathbf{4.8 \text{ V}}$$

Step 5: See Fig. 9.42.

The importance of marking the terminals should be obvious from Example 9.8. Note that there is no requirement that the Thévenin voltage have the same polarity as the equivalent circuit originally introduced.

EXAMPLE 9.9 Find the Thévenin equivalent circuit for the network in the shaded area of the bridge network in Fig. 9.43.

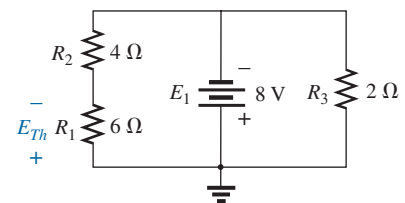
FIG. 9.41

Network of Fig. 9.40 redrawn.

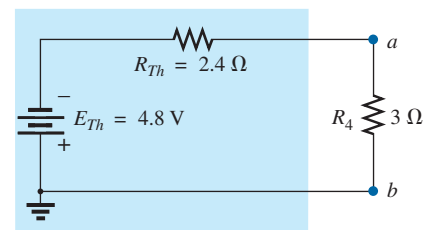
FIG. 9.42

Substituting the Thévenin equivalent circuit for the network external to the resistor R_4 in Fig. 9.37.

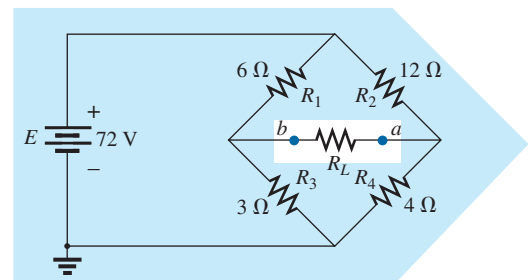
FIG. 9.43

Example 9.9.

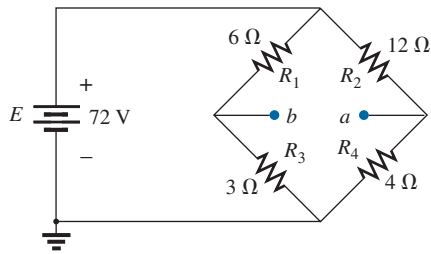

FIG. 9.44

Identifying the terminals of particular interest for the network in Fig. 9.43.

Solution:

Steps 1 and 2: See Fig. 9.44.

Step 3: See Fig. 9.45. In this case, the short-circuit replacement of the voltage source E provides a direct connection between c and c' in Fig. 9.45(a), permitting a “folding” of the network around the horizontal line of a - b to produce the configuration in Fig. 9.45(b).

$$\begin{aligned} R_{Th} &= R_{a-b} = R_1 \parallel R_3 + R_2 \parallel R_4 \\ &= 6 \Omega \parallel 3 \Omega + 4 \Omega \parallel 12 \Omega \\ &= 2 \Omega + 3 \Omega = 5 \Omega \end{aligned}$$

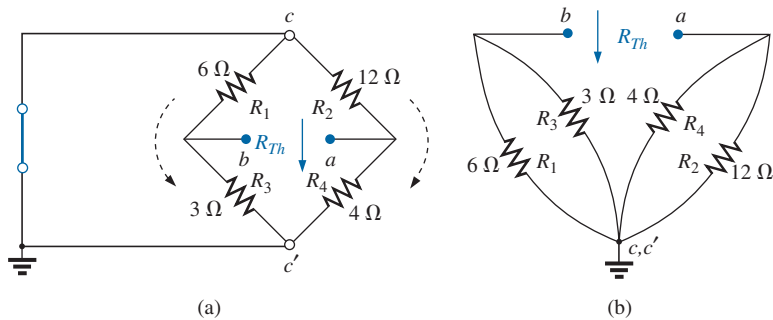

FIG. 9.45

Solving for R_{Th} for the network in Fig. 9.44.

Step 4: The circuit is redrawn in Fig. 9.46. The absence of a direct connection between a and b results in a network with three parallel branches. The voltages V_1 and V_2 can therefore be determined using the voltage divider rule:

$$\begin{aligned} V_1 &= \frac{R_1 E}{R_1 + R_3} = \frac{(6 \Omega)(72 \text{ V})}{6 \Omega + 3 \Omega} = \frac{432 \text{ V}}{9} = 48 \text{ V} \\ V_2 &= \frac{R_2 E}{R_2 + R_4} = \frac{(12 \Omega)(72 \text{ V})}{12 \Omega + 4 \Omega} = \frac{864 \text{ V}}{16} = 54 \text{ V} \end{aligned}$$

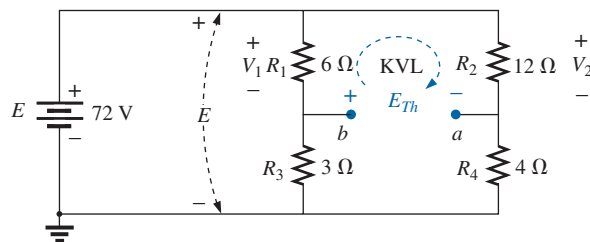

FIG. 9.46

Determining E_{Th} for the network in Fig. 9.44.

Assuming the polarity shown for E_{Th} and applying Kirchhoff's voltage law to the top loop in the clockwise direction results in

$$\sum_C V = +E_{Th} + V_1 - V_2 = 0$$

and

$$E_{Th} = V_2 - V_1 = 54 \text{ V} - 48 \text{ V} = 6 \text{ V}$$

Step 5: See Fig. 9.47.

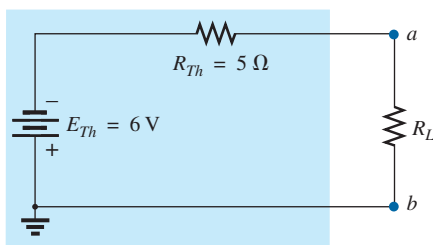

FIG. 9.47

Substituting the Thévenin equivalent circuit for the network external to the resistor R_L in Fig. 9.43.



Thévenin's theorem is not restricted to a single passive element, as shown in the preceding examples, but can be applied across sources, whole branches, portions of networks, or any circuit configuration, as shown in the following example. It is also possible that you may have to use one of the methods previously described, such as mesh analysis or superposition, to find the Thévenin equivalent circuit.

EXAMPLE 9.10 (Two sources) Find the Thévenin circuit for the network within the shaded area of Fig. 9.48.

Solution:

Steps 1 and 2: See Fig. 9.49. The network is redrawn.

Step 3: See Fig. 9.50.

$$\begin{aligned} R_{Th} &= R_4 + R_1 \parallel R_2 \parallel R_3 \\ &= 1.4 \text{ k}\Omega + 0.8 \text{ k}\Omega \parallel 4 \text{ k}\Omega \parallel 6 \text{ k}\Omega \\ &= 1.4 \text{ k}\Omega + 0.8 \text{ k}\Omega \parallel 2.4 \text{ k}\Omega \\ &= 1.4 \text{ k}\Omega + 0.6 \text{ k}\Omega \\ &= \mathbf{2 \text{ k}\Omega} \end{aligned}$$

Step 4: Applying superposition, we will consider the effects of the voltage source E_1 first. Note Fig. 9.51. The open circuit requires that $V_4 = I_4 R_4 = (0)R_4 = 0 \text{ V}$, and

$$\begin{aligned} E'_{Th} &= V_3 \\ R'_T &= R_2 \parallel R_3 = 4 \text{ k}\Omega \parallel 6 \text{ k}\Omega = 2.4 \text{ k}\Omega \end{aligned}$$

Applying the voltage divider rule gives

$$\begin{aligned} V_3 &= \frac{R'_T E_1}{R'_T + R_1} = \frac{(2.4 \text{ k}\Omega)(6 \text{ V})}{2.4 \text{ k}\Omega + 0.8 \text{ k}\Omega} = \frac{14.4 \text{ V}}{3.2} = 4.5 \text{ V} \\ E'_{Th} &= V_3 = 4.5 \text{ V} \end{aligned}$$

For the source E_2 , the network in Fig. 9.52 results. Again, $V_4 = I_4 R_4 = (0)R_4 = 0 \text{ V}$, and

$$\begin{aligned} E''_{Th} &= V_3 \\ R'_T &= R_1 \parallel R_3 = 0.8 \text{ k}\Omega \parallel 6 \text{ k}\Omega = 0.706 \text{ k}\Omega \end{aligned}$$

and

$$\begin{aligned} V_3 &= \frac{R'_T E_2}{R'_T + R_2} = \frac{(0.706 \text{ k}\Omega)(10 \text{ V})}{0.706 \text{ k}\Omega + 4 \text{ k}\Omega} = \frac{7.06 \text{ V}}{4.706} = 1.5 \text{ V} \\ E''_{Th} &= V_3 = 1.5 \text{ V} \end{aligned}$$

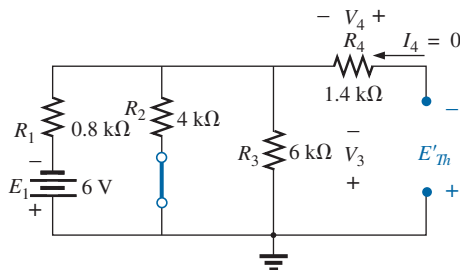

FIG. 9.51

Determining the contribution to E_{Th} from the source E_1 for the network in Fig. 9.49.

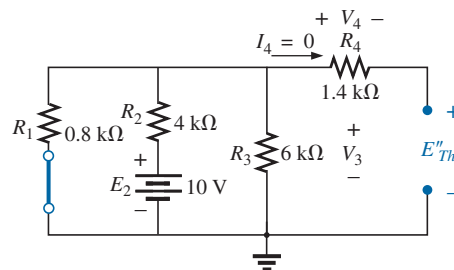

FIG. 9.52

Determining the contribution to E_{Th} from the source E_2 for the network in Fig. 9.49.

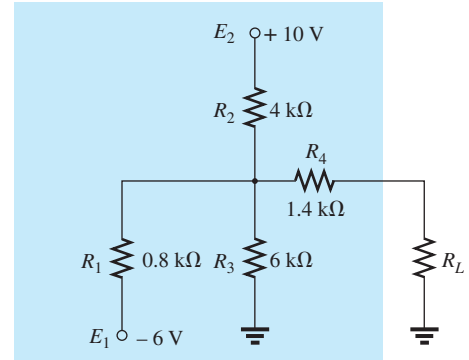

FIG. 9.48

Example 9.10.

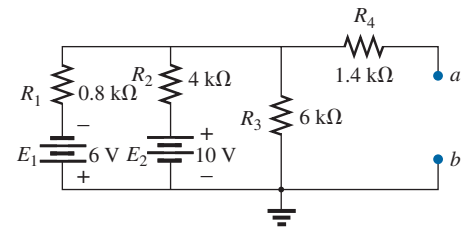

FIG. 9.49

Identifying the terminals of particular interest for the network in Fig. 9.48.

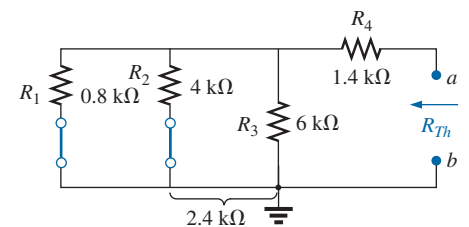

FIG. 9.50

Determining R_{Th} for the network in Fig. 9.49.

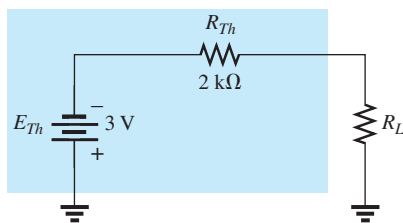

FIG. 9.53

Substituting the Thévenin equivalent circuit for the network external to the resistor R_L in Fig. 9.48.

Since E'_{Th} and E''_{Th} have opposite polarities,

$$\begin{aligned} E_{Th} &= E'_{Th} - E''_{Th} \\ &= 4.5 \text{ V} - 1.5 \text{ V} \\ &= \mathbf{3 \text{ V}} \quad (\text{polarity of } E'_{Th}) \end{aligned}$$

Step 5: See Fig. 9.53.

In the next example there is both a current source and voltage source in the configuration to be converted into a Thévenin equivalent circuit. In such cases it may be necessary to use the superposition theorem or a method of analysis to find the Thévenin voltage. Note also that the network outside the chosen area is more complex than a single element. In other words, portions of a more complex network can be replaced by their Thévenin equivalent circuit to further reduce the complexity of the original network.

EXAMPLE 9.11 For the network of Fig. 9.54,

- Find the Thévenin equivalent circuit for the portion of the network in the shaded area.
- Reconstruct the network of Fig. 9.54 with the Thévenin equivalent network in place.
- Using the resulting network of part (b) find the voltage V_a .

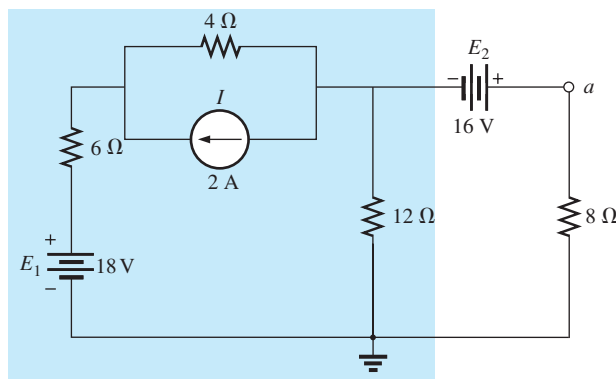

FIG. 9.54

Example 9.11.

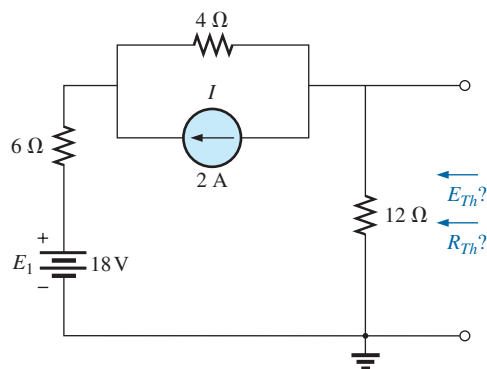

FIG. 9.55

Establishing the terminals of interest for the network of Fig. 9.54.

Solutions:

a. Steps 1 and 2: See Fig. 9.55.

Step 3: See Fig. 9.56.

$$R_{Th} = 12 \Omega \parallel (4 \Omega + 6 \Omega) = 12 \Omega \parallel 10 \Omega = \mathbf{5.45 \Omega}$$

Step 4: Applying the superposition theorem, we will first find the effect of the voltage source on the Thévenin voltage using the network of Fig. 9.57. Applying the voltage divider rule:

$$E'_{Th} = \frac{12 \Omega (18 \text{ V})}{6 \Omega + 4 \Omega + 12 \Omega} = \frac{216}{22} \text{ V} = 9.82 \text{ V}$$

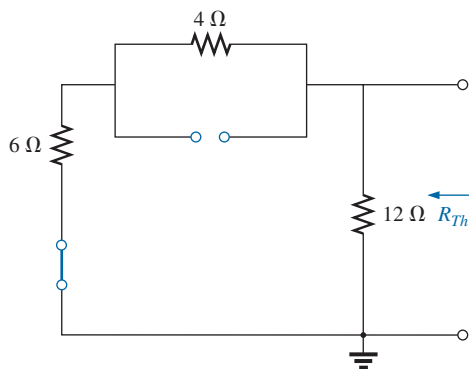

FIG. 9.56
Determining R_{Th} .

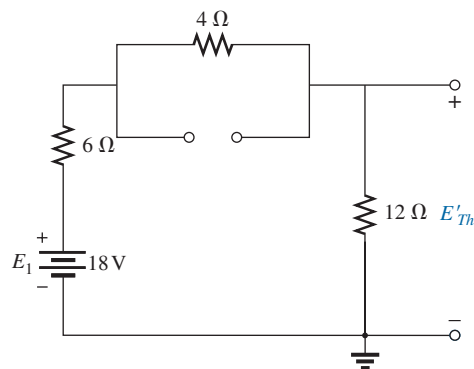
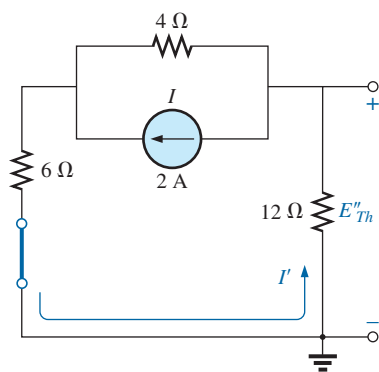
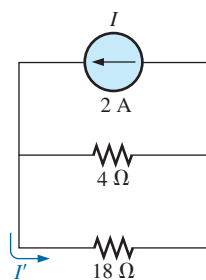

FIG. 9.57
Determining the contribution of E_1 to E_{Th} .



(a)



(b)

FIG. 9.58
Determining the contribution of I to E_{Th} .

The contribution due to the current source is determined using the network of Fig. 9.58(a) redrawn as shown in Fig. 9.58(b). Applying the current divider rule:

$$I' = \frac{4 \Omega (2 \text{ A})}{4 \Omega + 18 \Omega} = \frac{8}{22} \text{ A} = 0.364 \text{ A}$$

and $E''_{Th} = -I'(12 \Omega) = -(0.364 \text{ A})(12 \Omega) = -4.37 \text{ V}$

so that $E_{Th} = E'_{Th} + E''_{Th} = 9.82 \text{ V} - 4.37 \text{ V} = \mathbf{5.45 \text{ V}}$

- b. The reconstructed network is shown in Fig. 9.59.
- c. Using the voltage divider rule:

$$V_a = \frac{8 \Omega (5.45 \text{ V} + 16 \text{ V})}{5.45 \Omega + 8 \Omega} = \frac{8 (21.45)}{13.45} \text{ V} = \frac{171.6}{13.45} \text{ V} = \mathbf{12.76 \text{ V}}$$

Instead of using the superposition theorem, the current source could first have been converted to a voltage source and the series elements combined to determine the Thévenin voltage. In any event both approaches would have yielded the same results.

Experimental Procedures

Now that the analytical procedure has been described in detail and a sense for the Thévenin impedance and voltage established, it is time to

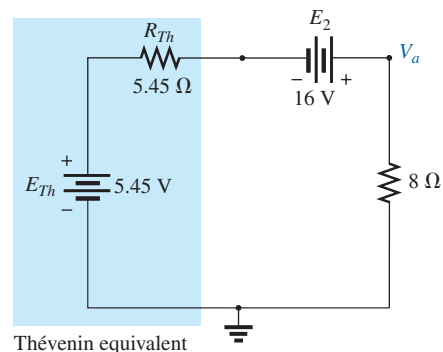

FIG. 9.59
Applying the Thévenin equivalent network to the network of Fig. 9.54.



investigate how both quantities can be determined using an experimental procedure.

Even though the Thévenin resistance is usually the easiest to determine analytically, the Thévenin voltage is often the easiest to determine experimentally, and therefore it will be examined first.

Measuring E_{Th} The network of Fig. 9.60(a) has the equivalent Thévenin circuit appearing in Fig. 9.60(b). The open-circuit Thévenin voltage can be determined by simply placing a voltmeter on the output terminals in Fig. 9.60(a) as shown. This is due to the fact that the open circuit in Fig. 9.60(b) dictates that the current through and the voltage across the Thévenin resistance must be zero. The result for Fig. 9.60(b) is that

$$V_{oc} = E_{Th} = 4.5 \text{ V}$$

In general, therefore,

the Thévenin voltage is determined by connecting a voltmeter to the output terminals of the network. Be sure the internal resistance of the voltmeter is significantly more than the expected level of R_{Th} .

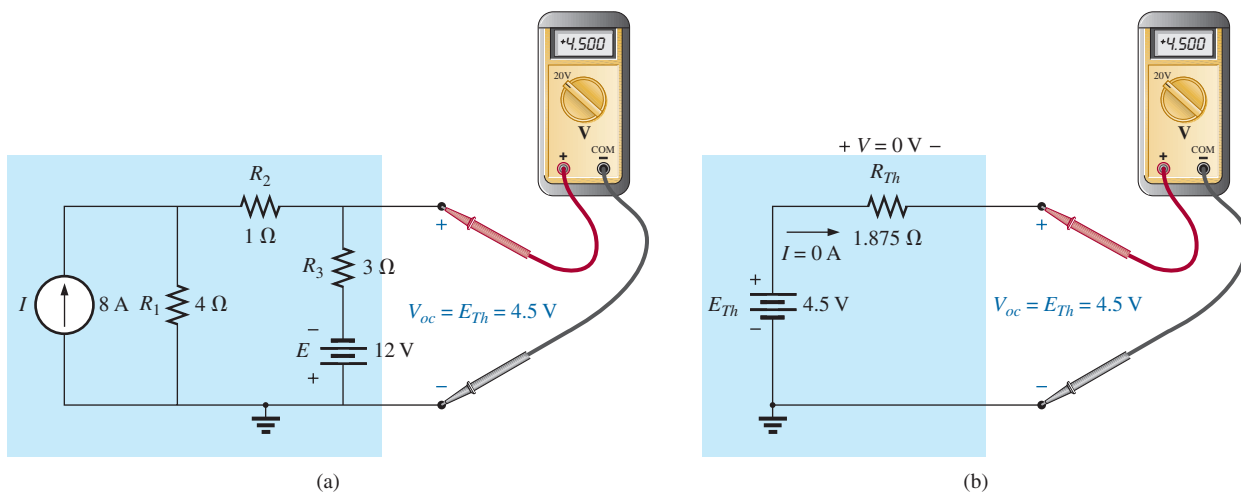

FIG. 9.60

Measuring the Thévenin voltage with a voltmeter: (a) actual network; (b) Thévenin equivalent.

Measuring R_{Th}

Using An Ohmmeter In Fig. 9.61, the sources in Fig. 9.60(a) have been set to zero, and an ohmmeter has been applied to measure the Thévenin resistance. In Fig. 9.60(b), it is clear that if the Thévenin voltage is set to zero volts, the ohmmeter will read the Thévenin resistance directly.

In general, therefore,

the Thévenin resistance can be measured by setting all the sources to zero and measuring the resistance at the output terminals.

It is important to remember, however, that ohmmeters cannot be used on live circuits, and you cannot set a voltage source by putting a short circuit across it—it causes instant damage. The source must either be set to zero or removed entirely and then replaced by a direct connection. For

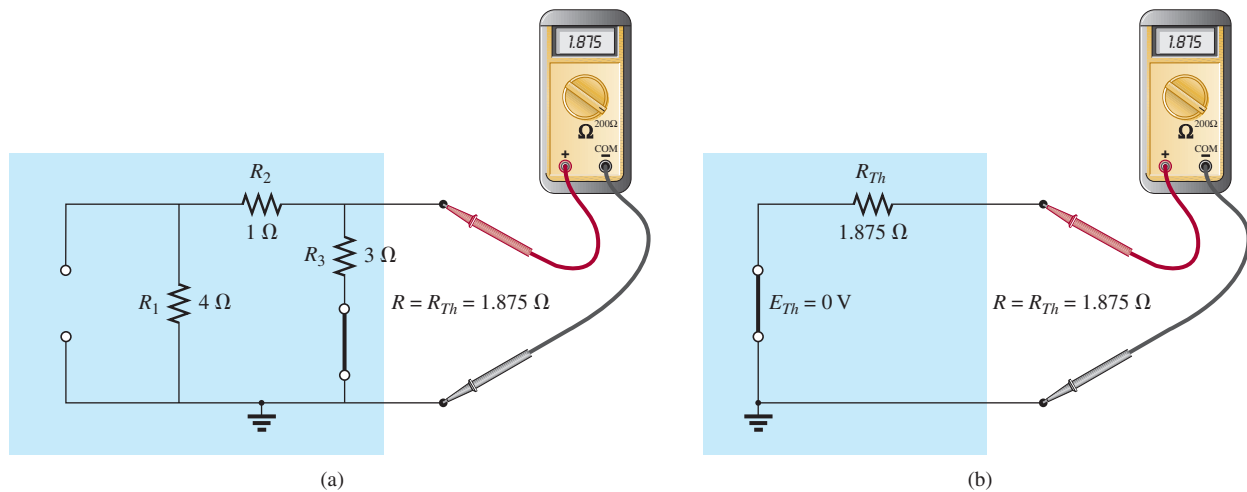
FIG. 9.61

Measuring R_{Th} with an ohmmeter: (a) actual network; (b) Thévenin equivalent.

the current source, the open-circuit condition must be clearly established; otherwise, the measured resistance will be incorrect. For most situations, it is usually best to remove the sources and replace them by the appropriate equivalent.

Using a Potentiometer If we use a potentiometer to measure the Thévenin resistance, the sources can be left as is. For this reason alone, this approach is one of the more popular. In Fig. 9.62(a), a potentiometer has been connected across the output terminals of the network to establish the condition appearing in Fig. 9.62(b) for the Thévenin equivalent. If the resistance of the potentiometer is now adjusted so that the voltage across the potentiometer is one-half the measured Thévenin voltage, the Thévenin resistance must match that of the potentiometer. Recall that for a series circuit, the applied voltage will divide equally across two equal series resistors.

If the potentiometer is then disconnected and the resistance measured with an ohmmeter as shown in Fig. 9.62(c), the ohmmeter displays the Thévenin resistance of the network. In general, therefore,

the Thévenin resistance can be measured by applying a potentiometer to the output terminals and varying the resistance until the output voltage is one-half the measured Thévenin voltage. The resistance of the potentiometer is the Thévenin resistance for the network.

Using the Short-Circuit Current The Thévenin resistance can also be determined by placing a short circuit across the output terminals and finding the current through the short circuit. Since ammeters ideally have zero internal ohms between their terminals, hooking up an ammeter as shown in Fig. 9.63(a) has the effect of both hooking up a short circuit across the terminals and measuring the resulting current. The same ammeter was connected across the Thévenin equivalent circuit in Fig. 9.63(b).

On a practical level, it is assumed, of course, that the internal resistance of the ammeter is approximately zero ohms in comparison to the other resistors of the network. It is also important to be sure that the resulting current does not exceed the maximum current for the chosen ammeter scale.

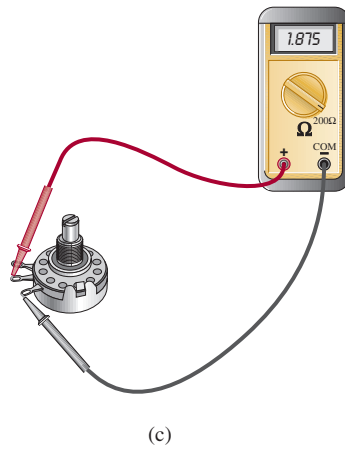
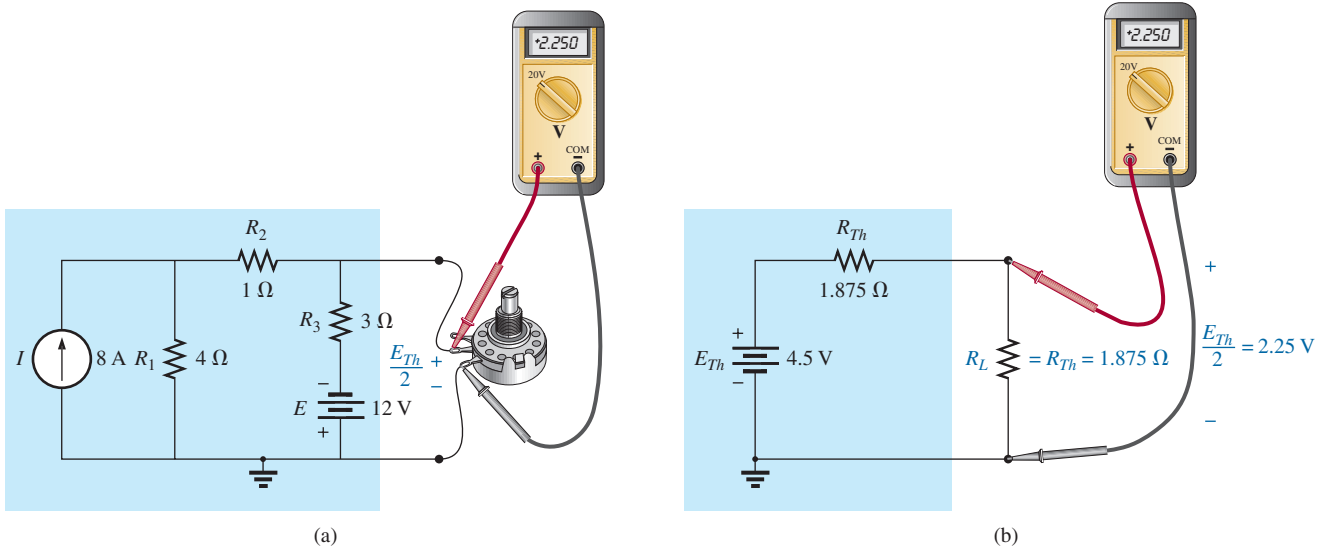

FIG. 9.62

Using a potentiometer to determine R_{Th} : (a) actual network; (b) Thévenin equivalent; (c) measuring R_{Th} .

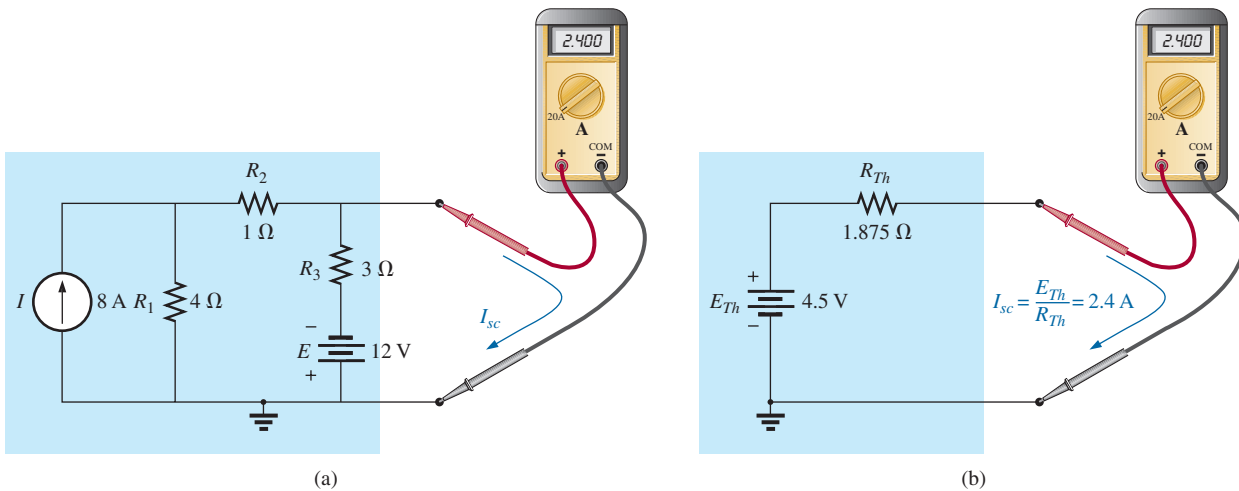

FIG. 9.63

Determining R_{Th} using the short-circuit current: (a) actual network; (b) Thévenin equivalent.



In Fig. 9.63(b), since the short-circuit current is

$$I_{sc} = \frac{E_{Th}}{R_{Th}}$$

the Thévenin resistance can be determined by

$$R_{Th} = \frac{E_{Th}}{I_{sc}}$$

In general, therefore,

the Thévenin resistance can be determined by hooking up an ammeter across the output terminals to measure the short-circuit current and then using the open-circuit voltage to calculate the Thévenin resistance in the following manner:

$$R_{Th} = \frac{V_{oc}}{I_{sc}} \quad (9.1)$$

As a result, we have three ways to measure the Thévenin resistance of a configuration. Because of the concern about setting the sources to zero in the first procedure and the concern about current levels in the last, the second method is often chosen.

9.4 NORTON'S THEOREM

In Section 8.2, we learned that every voltage source with a series internal resistance has a current source equivalent. The current source equivalent can be determined by **Norton's theorem** (Fig. 9.64). It can also be found through the conversions of Section 8.2.

The theorem states the following:

Any two-terminal linear bilateral dc network can be replaced by an equivalent circuit consisting of a current source and a parallel resistor, as shown in Fig. 9.65.

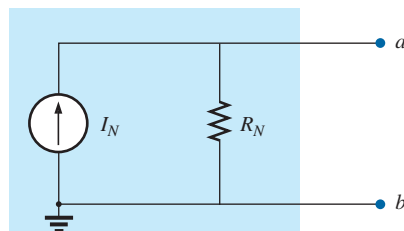

FIG. 9.65

Norton equivalent circuit.

The discussion of Thévenin's theorem with respect to the equivalent circuit can also be applied to the Norton equivalent circuit. The steps leading to the proper values of I_N and R_N are now listed.

Norton's Theorem Procedure

Preliminary:

1. *Remove that portion of the network across which the Norton equivalent circuit is found.*
2. *Mark the terminals of the remaining two-terminal network.*

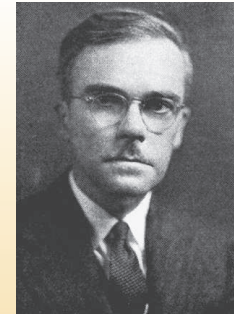

FIG. 9.64

Edward L. Norton.

Reprinted with the permission of
Lucent Technologies, Inc./Bell Labs.

American (Rockland, Maine; Summit, New Jersey)
1898–1983

Electrical Engineer, Scientist, Inventor

Department Head: Bell Laboratories

Fellow: Acoustical Society and Institute of Radio
Engineers

Although interested primarily in communications circuit theory and the transmission of data at high speeds over telephone lines, Edward L. Norton is best remembered for development of the dual of Thévenin equivalent circuit, currently referred to as *Norton's equivalent circuit*. In fact, Norton and his associates at AT&T in the early 1920s are recognized as being among the first to perform work applying Thévenin's equivalent circuit and referring to this concept simply as Thévenin's theorem. In 1926, he proposed the equivalent circuit using a current source and parallel resistor to assist in the design of recording instrumentation that was primarily current driven. He began his telephone career in 1922 with the Western Electric Company's Engineering Department, which later became Bell Laboratories. His areas of active research included network theory, acoustical systems, electromagnetic apparatus, and data transmission. A graduate of MIT and Columbia University, he held nineteen patents on his work.

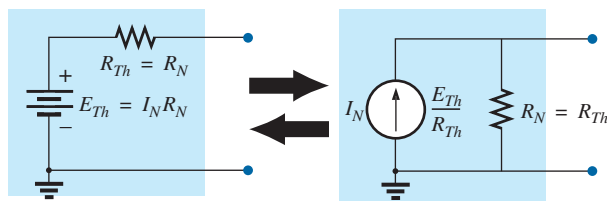

FIG. 9.66

Converting between Thévenin and Norton equivalent circuits.

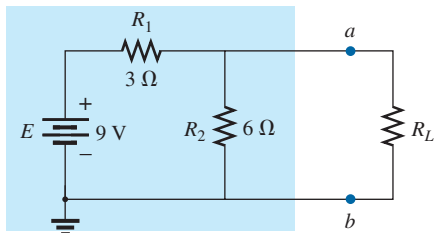

FIG. 9.67

Example 9.12.

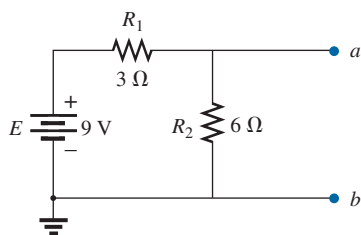

FIG. 9.68

Identifying the terminals of particular interest for the network in Fig. 9.67.

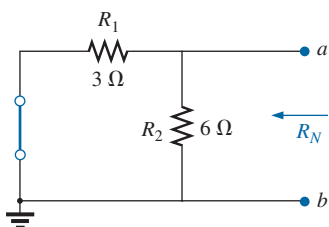

FIG. 9.69

Determining R_N for the network in Fig. 9.68.

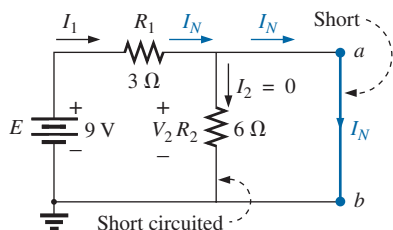

FIG. 9.70

Determining I_N for the network in Fig. 9.68.

R_N :

3. Calculate R_N by first setting all sources to zero (voltage sources are replaced with short circuits and current sources with open circuits) and then finding the resultant resistance between the two marked terminals. (If the internal resistance of the voltage and/or current sources is included in the original network, it must remain when the sources are set to zero.) Since $R_N = R_{Th}$, the procedure and value obtained using the approach described for Thévenin's theorem will determine the proper value of R_N .

I_N :

4. Calculate I_N by first returning all sources to their original position and then finding the short-circuit current between the marked terminals. It is the same current that would be measured by an ammeter placed between the marked terminals.

Conclusion:

5. Draw the Norton equivalent circuit with the portion of the circuit previously removed replaced between the terminals of the equivalent circuit.

The Norton and Thévenin equivalent circuits can also be found from each other by using the source transformation discussed earlier in this chapter and reproduced in Fig. 9.66.

EXAMPLE 9.12 Find the Norton equivalent circuit for the network in the shaded area in Fig. 9.67.

Solution:

Steps 1 and 2: See Fig. 9.68.

Step 3: See Fig. 9.69, and

$$R_N = R_1 \parallel R_2 = 3 \Omega \parallel 6 \Omega = \frac{(3 \Omega)(6 \Omega)}{3 \Omega + 6 \Omega} = \frac{18 \Omega}{9} = 2 \Omega$$

Step 4: See Fig. 9.70, which clearly indicates that the short-circuit connection between terminals a and b is in parallel with R_2 and eliminates its effect. I_N is therefore the same as through R_1 , and the full battery voltage appears across R_1 since

$$V_2 = I_2 R_2 = (0)6 \Omega = 0 \text{ V}$$

Therefore,

$$I_N = \frac{E}{R_1} = \frac{9 \text{ V}}{3 \Omega} = 3 \text{ A}$$

Step 5: See Fig. 9.71. This circuit is the same as the first one considered in the development of Thévenin's theorem. A simple conversion indicates that the Thévenin circuits are, in fact, the same (Fig. 9.72).

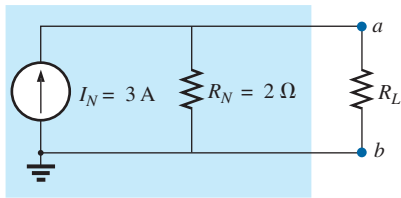

FIG. 9.71

Substituting the Norton equivalent circuit for the network external to the resistor R_L in Fig. 9.67.

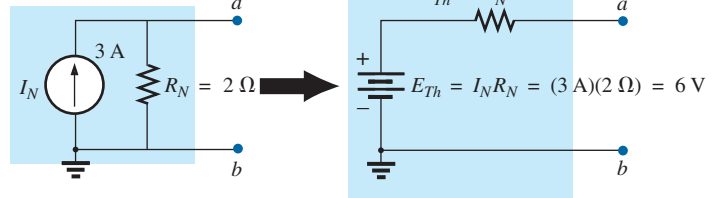

FIG. 9.72

Converting the Norton equivalent circuit in Fig. 9.71 to a Thévenin equivalent circuit.

EXAMPLE 9.13 Find the Norton equivalent circuit for the network external to the $9\ \Omega$ resistor in Fig. 9.73.

Solution:

Steps 1 and 2: See Fig. 9.74.

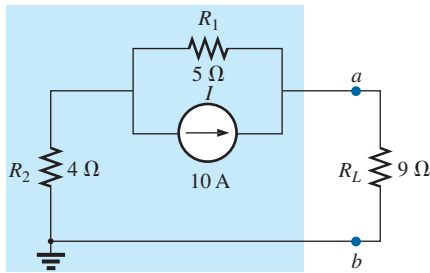

FIG. 9.73

Example 9.13.

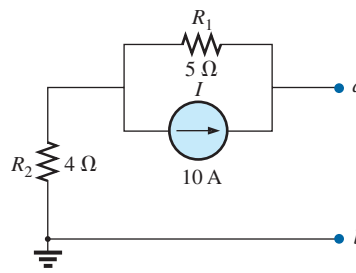

FIG. 9.74

Identifying the terminals of particular interest for the network in Fig. 9.73.

Step 3: See Fig. 9.75, and

$$R_N = R_1 + R_2 = 5\ \Omega + 4\ \Omega = 9\ \Omega$$

Step 4: As shown in Fig. 9.76, the Norton current is the same as the current through the $4\ \Omega$ resistor. Applying the current divider rule gives

$$I_N = \frac{R_1 I}{R_1 + R_2} = \frac{(5\ \Omega)(10\ \text{A})}{5\ \Omega + 4\ \Omega} = \frac{50\ \text{A}}{9} = 5.56\ \text{A}$$

Step 5: See Fig. 9.77.

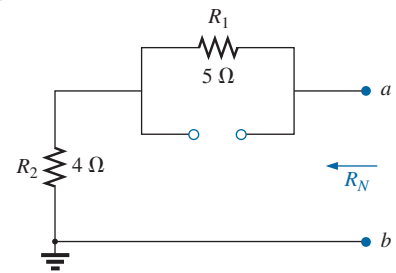

FIG. 9.75

Determining R_N for the network in Fig. 9.74.

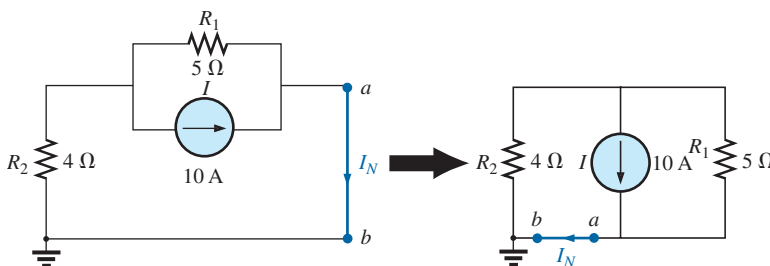

FIG. 9.76

Determining I_N for the network in Fig. 9.74.

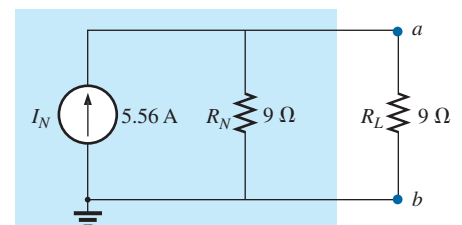

FIG. 9.77

Substituting the Norton equivalent circuit for the network external to the resistor R_L in Fig. 9.73.

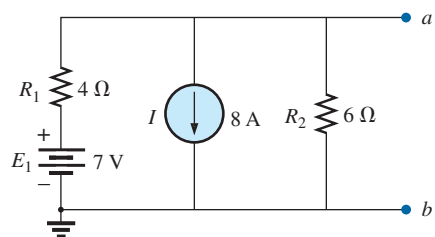

FIG. 9.79

Identifying the terminals of particular interest for the network in Fig. 9.78.

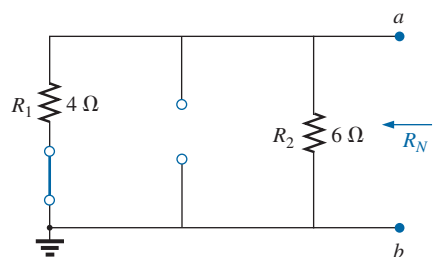

FIG. 9.80

Determining R_N for the network in Fig. 9.79.

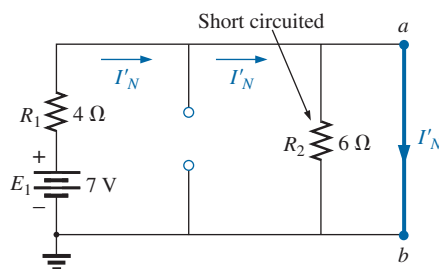

FIG. 9.81

Determining the contribution to I_N from the voltage source E_1 .

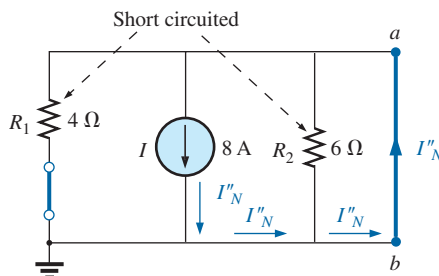

FIG. 9.82

Determining the contribution to I_N from the current source I .

EXAMPLE 9.14 (Two sources) Find the Norton equivalent circuit for the portion of the network to the left of $a-b$ in Fig. 9.78.

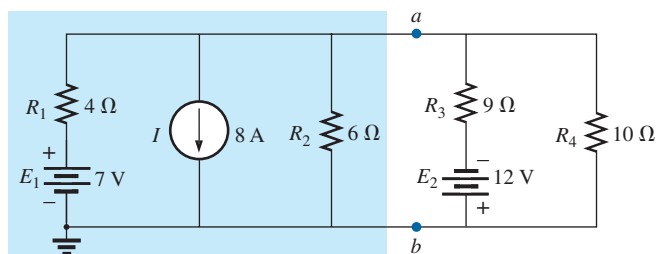

FIG. 9.78

Example 9.14.

Solution:

Steps 1 and 2: See Fig. 9.79.

Step 3: See Fig. 9.80, and

$$R_N = R_1 \parallel R_2 = 4 \Omega \parallel 6 \Omega = \frac{(4 \Omega)(6 \Omega)}{4 \Omega + 6 \Omega} = \frac{24 \Omega}{10} = 2.4 \Omega$$

Step 4: (Using superposition) For the 7 V battery (Fig. 9.81),

$$I'_N = \frac{E_1}{R_1} = \frac{7 \text{ V}}{4 \Omega} = 1.75 \text{ A}$$

For the 8 A source (Fig. 9.82), we find that both R_1 and R_2 have been “short circuited” by the direct connection between a and b , and

$$I''_N = I = 8 \text{ A}$$

The result is

$$I_N = I''_N - I'_N = 8 \text{ A} - 1.75 \text{ A} = 6.25 \text{ A}$$

Step 5: See Fig. 9.83.

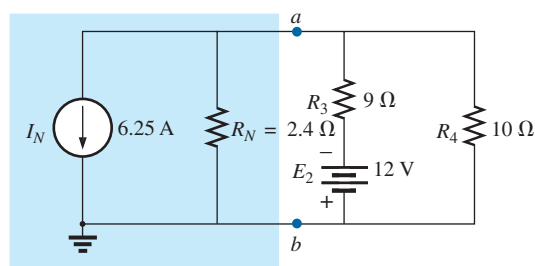

FIG. 9.83

Substituting the Norton equivalent circuit for the network to the left of terminals $a-b$ in Fig. 9.78.

Experimental Procedure

The Norton current is measured in the same way as described for the short-circuit current (I_{sc}) for the Thévenin network. Since the Norton and Thévenin resistances are the same, the same procedures can be followed as described for the Thévenin network.



9.5 MAXIMUM POWER TRANSFER THEOREM

When designing a circuit, it is often important to be able to answer one of the following questions:

What load should be applied to a system to ensure that the load is receiving maximum power from the system?

Conversely:

For a particular load, what conditions should be imposed on the source to ensure that it will deliver the maximum power available?

Even if a load cannot be set at the value that would result in maximum power transfer, it is often helpful to have some idea of the value that will draw maximum power so that you can compare it to the load at hand. For instance, if a design calls for a load of $100\ \Omega$, to ensure that the load receives maximum power, using a resistor of $1\ \Omega$ or $1\ \text{k}\Omega$ results in a power transfer that is much less than the maximum possible. However, using a load of $82\ \Omega$ or $120\ \Omega$ probably results in a fairly good level of power transfer.

Fortunately, the process of finding the load that will receive maximum power from a particular system is quite straightforward due to the **maximum power transfer theorem**, which states the following:

A load will receive maximum power from a network when its resistance is exactly equal to the Thévenin resistance of the network applied to the load. That is,

$$R_L = R_{Th} \quad (9.2)$$

In other words, for the Thévenin equivalent circuit in Fig. 9.84, when the load is set equal to the Thévenin resistance, the load will receive maximum power from the network.

Using Fig. 9.84 with $R_L = R_{Th}$, we can determine the maximum power delivered to the load by first finding the current:

$$I_L = \frac{E_{Th}}{R_{Th} + R_L} = \frac{E_{Th}}{R_{Th} + R_{Th}} = \frac{E_{Th}}{2R_{Th}}$$

Then we substitute into the power equation:

$$P_L = I_L^2 R_L = \left(\frac{E_{Th}}{2R_{Th}} \right)^2 (R_{Th}) = \frac{E_{Th}^2 R_{Th}}{4R_{Th}^2}$$

and

$$P_{L_{max}} = \frac{E_{Th}^2}{4R_{Th}} \quad (9.3)$$

To demonstrate that maximum power is indeed transferred to the load under the conditions defined above, consider the Thévenin equivalent circuit in Fig. 9.85.

Before getting into detail, however, if you were to guess what value of R_L would result in maximum power transfer to R_L , you might think that the smaller the value of R_L , the better it is because the current reaches a maximum when it is squared in the power equation. The problem is, however, that in the equation $P_L = I_L^2 R_L$, the load resistance is a multiplier. As it gets smaller, it forms a smaller product. Then again, you might suggest larger values of R_L because the output voltage increases, and power is determined by $P_L = V_L^2 / R_L$. This time, however, the load

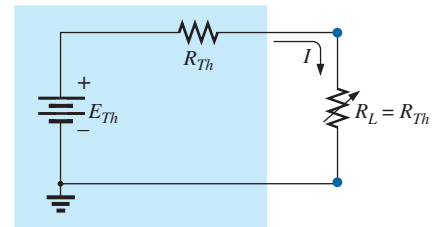

FIG. 9.84

Defining the conditions for maximum power to a load using the Thévenin equivalent circuit.

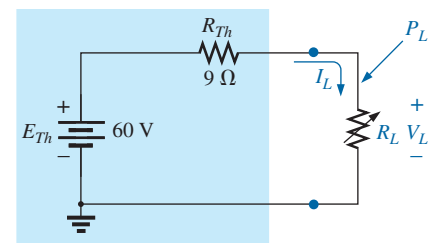

FIG. 9.85

Thévenin equivalent network to be used to validate the maximum power transfer theorem.



resistance is in the denominator of the equation and causes the resulting power to decrease. A balance must obviously be made between the load resistance and the resulting current or voltage. The following discussion shows that

maximum power transfer occurs when the load voltage and current are one-half their maximum possible values.

For the circuit in Fig. 9.85, the current through the load is determined by

$$I_L = \frac{E_{Th}}{R_{Th} + R_L} = \frac{60 \text{ V}}{9 \Omega + R_L}$$

The voltage is determined by

$$V_L = \frac{R_L E_{Th}}{R_L + R_{Th}} = \frac{R_L(60 \text{ V})}{R_L + R_{Th}}$$

and the power by

$$P_L = I_L^2 R_L = \left(\frac{60 \text{ V}}{9 \Omega + R_L} \right)^2 (R_L) = \frac{3600 R_L}{(9 \Omega + R_L)^2}$$

If we tabulate the three quantities versus a range of values for R_L from 0.1Ω to 30Ω , we obtain the results appearing in Table 9.1. Note in particular that when R_L is equal to the Thévenin resistance of 9Ω , the

TABLE 9.1

$R_L(\Omega)$	$P_L(\text{W})$	$I_L(\text{A})$	$V_L(\text{V})$
0.1	4.35	6.60	0.66
0.2	8.51	6.52	1.30
0.5	19.94	6.32	3.16
1	36.00	6.00	6.00
2	59.50	5.46	10.91
3	75.00	5.00	15.00
4	85.21	4.62	18.46
5	91.84	4.29	21.43
6	96.00	4.00	24.00
7	98.44	Increase	26.25
8	99.65	3.75	Increase
9 (R_{Th})	100.00 (Maximum)	3.33 ($I_{max}/2$)	30.00 ($E_{Th}/2$)
10	99.72	3.53	28.23
11	99.00	3.16	31.58
12	97.96	3.00	33.00
13	97.96	2.86	34.29
14	96.69	2.73	35.46
15	95.27	2.61	36.52
16	93.75	2.50	37.50
17	92.16	2.40	38.40
18	90.53	2.31	39.23
19	88.89	2.22	40.00
20	87.24	2.14	40.71
25	85.61	2.07	41.38
30	77.86	1.77	44.12
40	71.00	1.54	46.15
50	59.98	1.22	48.98
100	30.30	0.55	55.05
500	6.95	0.12	58.94
1000	3.54	0.06	59.47

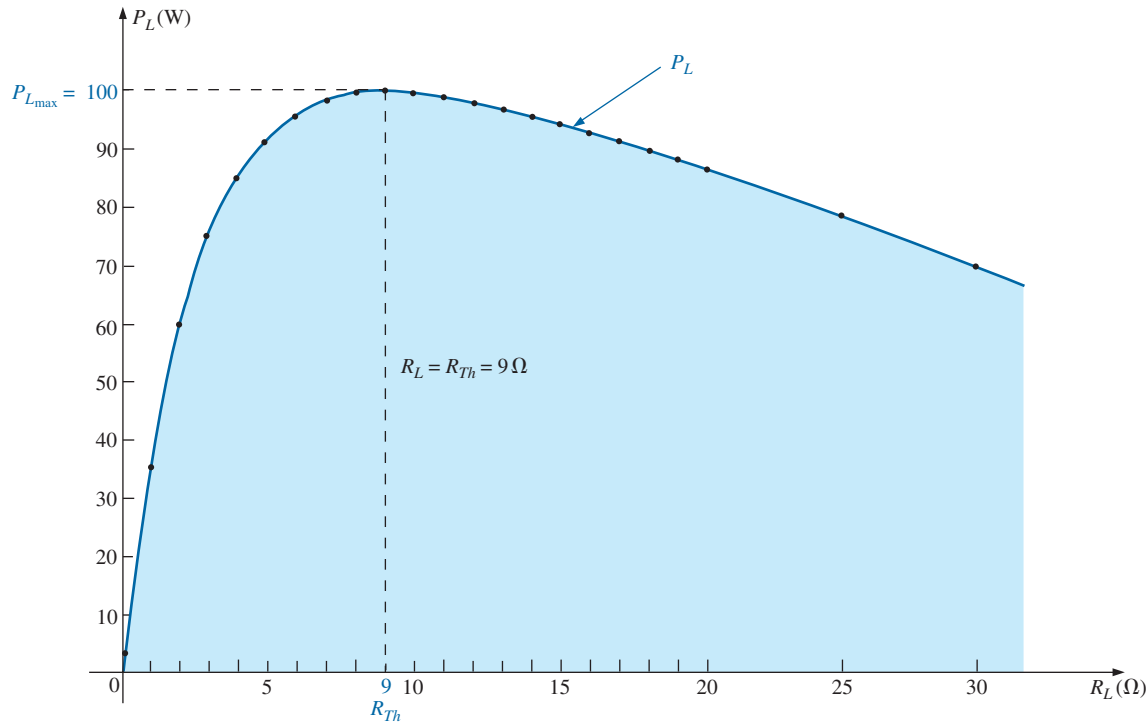
**FIG. 9.86**

P_L versus R_L for the network in Fig. 9.85.

power has a maximum value of 100 W, the current is 3.33 A, or one-half its maximum value of 6.67 A (as would result with a short circuit across the output terminals), and the voltage across the load is 30 V, or one-half its maximum value of 60 V (as would result with an open circuit across its output terminals). As you can see, there is no question that maximum power is transferred to the load when the load equals the Thévenin value.

The power to the load versus the range of resistor values is provided in Fig. 9.86. Note in particular that for values of load resistance less than the Thévenin value, the change is dramatic as it approaches the peak value. However, for values greater than the Thévenin value, the drop is a great deal more gradual. This is important because it tells us the following:

If the load applied is less than the Thévenin resistance, the power to the load will drop off rapidly as it gets smaller. However, if the applied load is greater than the Thévenin resistance, the power to the load will not drop off as rapidly as it increases.

For instance, the power to the load is at least 90 W for the range of about 4.5 Ω to 9 Ω below the peak value, but it is at least the same level for a range of about 9 Ω to 18 Ω above the peak value. The range below the peak is 4.5 Ω , while the range above the peak is almost twice as much as 9 Ω . As mentioned above, if maximum transfer conditions cannot be established, at least we now know from Fig. 9.86 that any resistance relatively close to the Thévenin value results in a strong transfer of power. More distant values such as 1 Ω or 100 Ω result in much lower levels.

It is particularly interesting to plot the power to the load versus load resistance using a log scale, as shown in Fig. 9.87. Logarithms will be discussed in detail in Chapter 22, but for now notice that the spacing

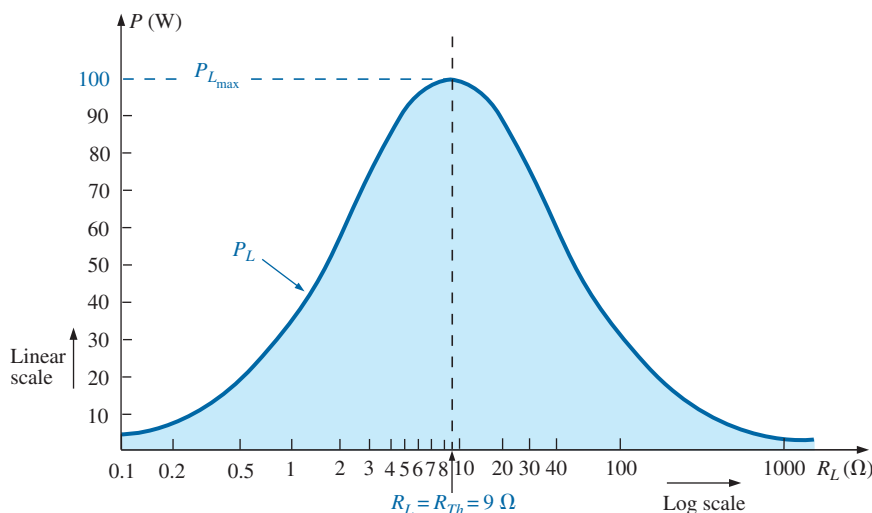

FIG. 9.87

P_L versus R_L for the network in Fig. 9.85.

between values of R_L is not linear, but the distance, between powers of ten (such as 0.1 and 1, 1 and 10, and 10 and 100) are all equal. The advantage of the log scale is that a wide resistance range can be plotted on a relatively small graph.

Note in Fig. 9.87 that a smooth, bell-shaped curve results that is symmetrical about the Thévenin resistance of $9\ \Omega$. At $0.1\ \Omega$, the power has dropped to about the same level as that at $1000\ \Omega$, and at $1\ \Omega$ and $100\ \Omega$, the power has dropped to the neighborhood of $30\ \text{W}$.

Although all of the above discussion centers on the power to the load, it is important to remember the following:

The total power delivered by a supply such as E_{Th} is absorbed by both the Thévenin equivalent resistance and the load resistance. Any power delivered by the source that does not get to the load is lost to the Thévenin resistance.

Under maximum power conditions, only half the power delivered by the source gets to the load. Now, that sounds disastrous, but remember that we are starting out with a fixed Thévenin voltage and resistance, and the above simply tells us that we must make the two resistance levels equal if we want maximum power to the load. On an efficiency basis, we are working at only a 50% level, but we are content because *we are getting maximum power out of our system*.

The dc operating efficiency is defined as the ratio of the power delivered to the load (P_L) to the power delivered by the source (P_s). That is,

$$\eta\% = \frac{P_L}{P_s} \times 100\% \quad (9.4)$$

For the situation where $R_L = R_{Th}$,

$$\begin{aligned} \eta\% &= \frac{I_L^2 R_L}{I_L^2 R_T} \times 100\% = \frac{R_L}{R_T} \times 100\% = \frac{R_{Th}}{R_{Th} + R_{Th}} \times 100\% \\ &= \frac{R_{Th}}{2R_{Th}} \times 100\% = \frac{1}{2} \times 100\% = \mathbf{50\%} \end{aligned}$$

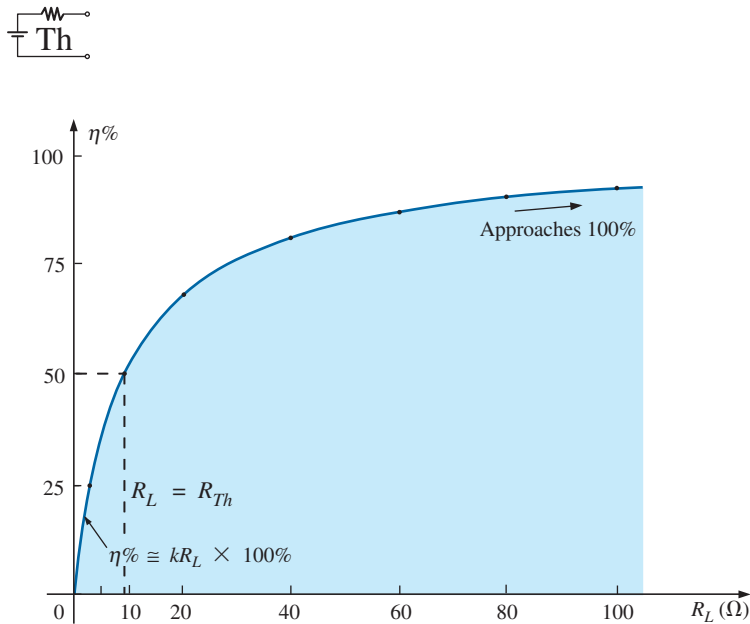
FIG. 9.88

Efficiency of operation versus increasing values of R_L .

For the circuit in Fig. 9.85, if we plot the efficiency of operation versus load resistance, we obtain the plot in Fig. 9.88, which clearly shows that the efficiency continues to rise to a 100% level as R_L gets larger. Note in particular that the efficiency is 50% when $R_L = R_{Th}$.

To ensure that you completely understand the effect of the maximum power transfer theorem and the efficiency criteria, consider the circuit in Fig. 9.89, where the load resistance is set at 100Ω and the power to the Thévenin resistance and to the load are calculated as follows:

$$I_L = \frac{E_{Th}}{R_{Th} + R_L} = \frac{60 \text{ V}}{9 \Omega + 100 \Omega} = \frac{60 \text{ V}}{109 \Omega} = 550.5 \text{ mA}$$

with $P_{R_{Th}} = I_L^2 R_{Th} = (550.5 \text{ mA})^2 (9 \Omega) \approx 2.73 \text{ W}$

and $P_L = I_L^2 R_L = (550.5 \text{ mA})^2 (100 \Omega) \approx 30.3 \text{ W}$

The results clearly show that most of the power supplied by the battery is getting to the load—a desirable attribute on an efficiency basis. However, the power getting to the load is only 30.3 W compared to the 100 W obtained under maximum power conditions. In general, therefore, the following guidelines apply:

If efficiency is the overriding factor, then the load should be much larger than the internal resistance of the supply. If maximum power transfer is desired and efficiency less of a concern, then the conditions dictated by the maximum power transfer theorem should be applied.

A relatively low efficiency of 50% can be tolerated in situations where power levels are relatively low, such as in a wide variety of electronic systems, where maximum power transfer for the given system is usually more important. However, when large power levels are involved, such as at generating plants, efficiencies of 50% cannot be tolerated. In fact, a great deal of expense and research is dedicated to raising power generating and transmission efficiencies a few percentage points. Raising an efficiency level of a 10 MkW power plant from 94% to 95% (a 1% increase) can save 0.1 MkW, or 100 million watts, of power—an enormous saving.

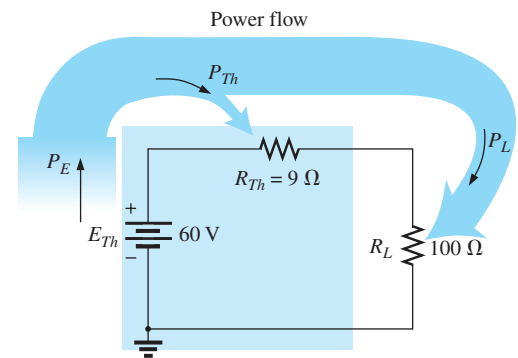
FIG. 9.89

Examining a circuit with high efficiency but a relatively low level of power to the load.

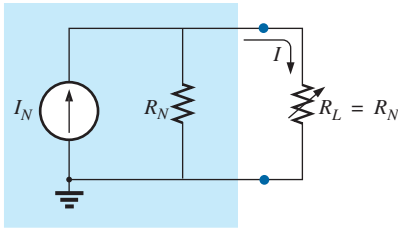

FIG. 9.90

Defining the conditions for maximum power to a load using the Norton equivalent circuit.

In all of the above discussions, the effect of changing the load was discussed for a fixed Thévenin resistance. Looking at the situation from a different viewpoint, we can say

if the load resistance is fixed and does not match the applied Thévenin equivalent resistance, then some effort should be made (if possible) to redesign the system so that the Thévenin equivalent resistance is closer to the fixed applied load.

In other words, if a designer faces a situation where the load resistance is fixed, he or she should investigate whether the supply section should be replaced or redesigned to create a closer match of resistance levels to produce higher levels of power to the load.

For the Norton equivalent circuit in Fig. 9.90, maximum power will be delivered to the load when

$$R_L = R_N \quad (9.5)$$

This result [Eq. (9.5)] will be used to its fullest advantage in the analysis of transistor networks, where the most frequently applied transistor circuit model uses a current source rather than a voltage source.

For the Norton circuit in Fig. 9.90,

$$P_{L_{\max}} = \frac{I_N^2 R_N}{4} \quad (\text{W}) \quad (9.6)$$

EXAMPLE 9.15 A dc generator, battery, and laboratory supply are connected to resistive load R_L in Fig. 9.91.

- For each, determine the value of R_L for maximum power transfer to R_L .
- Under maximum power conditions, what are the current level and the power to the load for each configuration?
- What is the efficiency of operation for each supply in part (b)?
- If a load of $1 \text{ k}\Omega$ were applied to the laboratory supply, what would the power delivered to the load be? Compare your answer to the level of part (b). What is the level of efficiency?
- For each supply, determine the value of R_L for 75% efficiency.

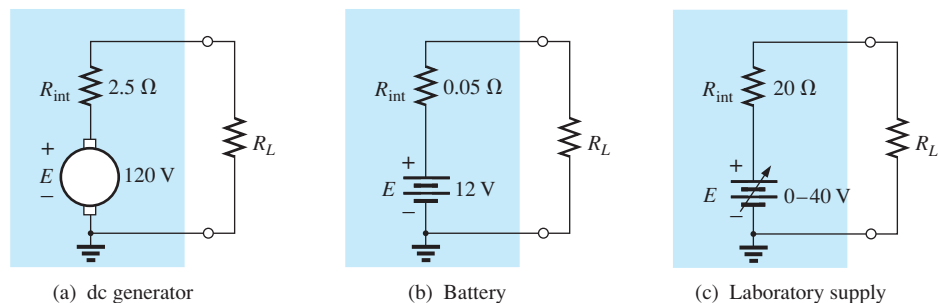

FIG. 9.91

Example 9.15.

Solutions:

- For the dc generator,

$$R_L = R_{Th} = R_{int} = 2.5 \Omega$$



For the 12 V car battery,

$$R_L = R_{Th} = R_{int} = \mathbf{0.05 \Omega}$$

For the dc laboratory supply,

$$R_L = R_{Th} = R_{int} = \mathbf{20 \Omega}$$

b. For the dc generator,

$$P_{L_{max}} = \frac{E_{Th}^2}{4R_{Th}} = \frac{E^2}{4R_{int}} = \frac{(120 \text{ V})^2}{4(2.5 \Omega)} = \mathbf{1.44 \text{ kW}}$$

For the 12 V car battery,

$$P_{L_{max}} = \frac{E_{Th}^2}{4R_{Th}} = \frac{E^2}{4R_{int}} = \frac{(12 \text{ V})^2}{4(0.05 \Omega)} = \mathbf{720 \text{ W}}$$

For the dc laboratory supply,

$$P_{L_{max}} = \frac{E_{Th}^2}{4R_{Th}} = \frac{E^2}{4R_{int}} = \frac{(40 \text{ V})^2}{4(20 \Omega)} = \mathbf{20 \text{ W}}$$

c. They are all operating under a 50% efficiency level because $R_L = R_{Th}$.

d. The power to the load is determined as follows:

$$I_L = \frac{E}{R_{int} + R_L} = \frac{40 \text{ V}}{20 \Omega + 1000 \Omega} = \frac{40 \text{ V}}{1020 \Omega} = 39.22 \text{ mA}$$

$$\text{and } P_L = I_L^2 R_L = (39.22 \text{ mA})^2 (1000 \Omega) = \mathbf{1.54 \text{ W}}$$

The power level is significantly less than the 20 W achieved in part (b). The efficiency level is

$$\begin{aligned} \eta\% &= \frac{P_L}{P_s} \times 100\% = \frac{1.54 \text{ W}}{EI_s} \times 100\% = \frac{1.54 \text{ W}}{(40 \text{ V})(39.22 \text{ mA})} \times 100\% \\ &= \frac{1.54 \text{ W}}{1.57 \text{ W}} \times 100\% = \mathbf{98.09\%} \end{aligned}$$

which is markedly higher than achieved under maximum power conditions—albeit at the expense of the power level.

e. For the dc generator,

$$\eta = \frac{P_o}{P_s} = \frac{R_L}{R_{Th} + R_L} \quad (\eta \text{ in decimal form})$$

$$\text{and } \eta = \frac{R_L}{R_{Th} + R_L}$$

$$\eta(R_{Th} + R_L) = R_L$$

$$\eta R_{Th} + \eta R_L = R_L$$

$$R_L(1 - \eta) = \eta R_{Th}$$

and

$$R_L = \frac{\eta R_{Th}}{1 - \eta} \quad \mathbf{(9.7)}$$

$$R_L = \frac{0.75(2.5 \Omega)}{1 - 0.75} = \mathbf{7.5 \Omega}$$

For the battery,

$$R_L = \frac{0.75(0.05 \Omega)}{1 - 0.75} = \mathbf{0.15 \Omega}$$

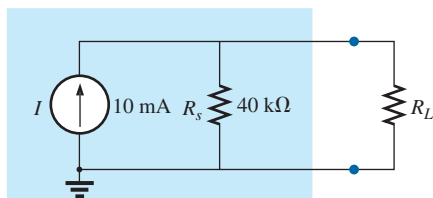

FIG. 9.92
Example 9.16.

For the laboratory supply,

$$R_L = \frac{0.75(20 \Omega)}{1 - 0.75} = 60 \Omega$$

EXAMPLE 9.16 The analysis of a transistor network resulted in the reduced equivalent in Fig. 9.92.

- Find the load resistance that will result in maximum power transfer to the load, and find the maximum power delivered.
- If the load were changed to $68 \text{ k}\Omega$, would you expect a fairly high level of power transfer to the load based on the results of part (a)? What would the new power level be? Is your initial assumption verified?
- If the load were changed to $8.2 \text{ k}\Omega$, would you expect a fairly high level of power transfer to the load based on the results of part (a)? What would the new power level be? Is your initial assumption verified?

Solutions:

- Replacing the current source by an open-circuit equivalent results in

$$R_{Th} = R_s = 40 \text{ k}\Omega$$

Restoring the current source and finding the open-circuit voltage at the output terminals results in

$$E_{Th} = V_{oc} = IR_s = (10 \text{ mA})(40 \text{ k}\Omega) = 400 \text{ V}$$

For maximum power transfer to the load,

$$R_L = R_{Th} = 40 \text{ k}\Omega$$

with a maximum power level of

$$P_{L_{\max}} = \frac{E_{Th}^2}{4R_{Th}} = \frac{(400 \text{ V})^2}{4(40 \text{ k}\Omega)} = 1 \text{ W}$$

- Yes, because the $68 \text{ k}\Omega$ load is greater (note Fig. 9.86) than the $40 \text{ k}\Omega$ load, but relatively close in magnitude.

$$I_L = \frac{E_{Th}}{R_{Th} + R_L} = \frac{400 \text{ V}}{40 \text{ k}\Omega + 68 \text{ k}\Omega} = \frac{400}{108 \text{ k}\Omega} \cong 3.7 \text{ mA}$$

$$P_L = I_L^2 R_L = (3.7 \text{ mA})^2 (68 \text{ k}\Omega) \cong 0.93 \text{ W}$$

Yes, the power level of 0.93 W compared to the 1 W level of part (a) verifies the assumption.

- No, $8.2 \text{ k}\Omega$ is quite a bit less (note Fig. 9.86) than the $40 \text{ k}\Omega$ value.

$$I_L = \frac{E_{Th}}{R_{Th} + R_L} = \frac{400 \text{ V}}{40 \text{ k}\Omega + 8.2 \text{ k}\Omega} = \frac{400 \text{ V}}{48.2 \text{ k}\Omega} \cong 8.3 \text{ mA}$$

$$P_L = I_L^2 R_L = (8.3 \text{ mA})^2 (8.2 \text{ k}\Omega) \cong 0.57 \text{ W}$$

Yes, the power level of 0.57 W compared to the 1 W level of part (a) verifies the assumption.

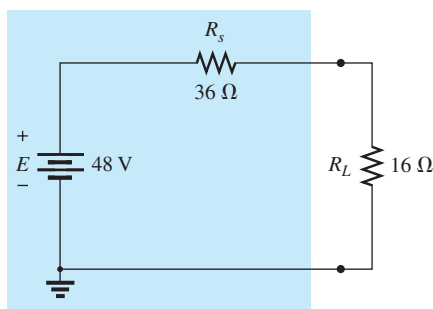

dc supply

FIG. 9.93
dc supply with a fixed 16Ω load (Example 9.17).

EXAMPLE 9.17 In Fig. 9.93, a fixed load of 16Ω is applied to a 48 V supply with an internal resistance of 36Ω .

- For the conditions in Fig. 9.93, what is the power delivered to the load and lost to the internal resistance of the supply?
- If the designer has some control over the internal resistance level of the supply, what value should he or she make it for maximum power to the load? What is the maximum power to the load? How does it compare to the level obtained in part (a)?
- Without making a single calculation, find the value that would result in more power to the load if the designer could change the internal resistance to $22\ \Omega$ or $8.2\ \Omega$. Verify your conclusion by calculating the power to the load for each value.

Solutions:

$$\text{a. } I_L = \frac{E}{R_s + R_L} = \frac{48\ \text{V}}{36\ \Omega + 16\ \Omega} = \frac{48\ \text{V}}{52\ \Omega} = 923.1\ \text{mA}$$

$$P_{R_s} = I_L^2 R_s = (923.1\ \text{mA})^2 (36\ \Omega) = \mathbf{30.68\ \text{W}}$$

$$P_L = I_L^2 R_L = (923.1\ \text{mA})^2 (16\ \Omega) = \mathbf{13.63\ \text{W}}$$

- Be careful here. The quick response is to make the source resistance R_s equal to the load resistance to satisfy the criteria of the maximum power transfer theorem. However, this is a totally different type of problem from what was examined earlier in this section. If the load is fixed, the smaller the source resistance R_s , the more applied voltage will reach the load and the less will be lost in the internal series resistor. In fact, the source resistance should be made as small as possible. If zero ohms were possible for R_s , the voltage across the load would be the full supply voltage, and the power delivered to the load would equal

$$P_L = \frac{V_L^2}{R_L} = \frac{(48\ \text{V})^2}{16\ \Omega} = \mathbf{144\ \text{W}}$$

which is more than 10 times the value with a source resistance of $36\ \Omega$.

- Again, forget the impact in Fig. 9.86: The smaller the source resistance, the greater is the power to the fixed $16\ \Omega$ load. Therefore, the $8.2\ \Omega$ resistance level results in a higher power transfer to the load than the $22\ \Omega$ resistor.

For $R_s = 8.2\ \Omega$

$$I_L = \frac{E}{R_s + R_L} = \frac{48\ \text{V}}{8.2\ \Omega + 16\ \Omega} = \frac{48\ \text{V}}{24.2\ \Omega} = 1.983\ \text{A}$$

and $P_L = I_L^2 R_L = (1.983\ \text{A})^2 (16\ \Omega) \cong \mathbf{62.92\ \text{W}}$

For $R_s = 22\ \Omega$

$$I_L = \frac{E}{R_s + R_L} = \frac{48\ \text{V}}{22\ \Omega + 16\ \Omega} = \frac{48\ \text{V}}{38\ \Omega} = 1.263\ \text{A}$$

and $P_L = I_L^2 R_L = (1.263\ \text{A})^2 (16\ \Omega) \cong \mathbf{25.52\ \text{W}}$

EXAMPLE 9.18 Given the network in Fig. 9.94, find the value of R_L for maximum power to the load, and find the maximum power to the load.

Solution: The Thévenin resistance is determined from Fig. 9.95:

$$R_{Th} = R_1 + R_2 + R_3 = 3\ \Omega + 10\ \Omega + 2\ \Omega = 15\ \Omega$$

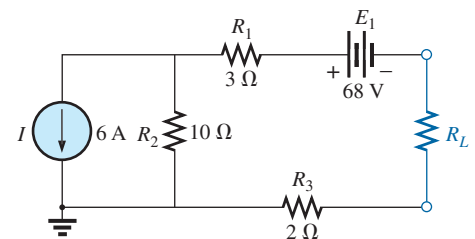

FIG. 9.94

Example 9.18.

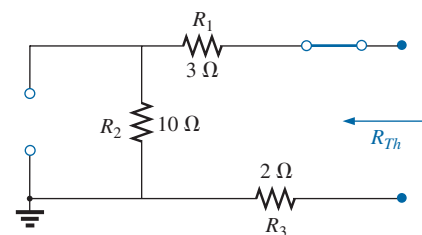

FIG. 9.95

Determining R_{Th} for the network external to resistor R_L in Fig. 9.94.

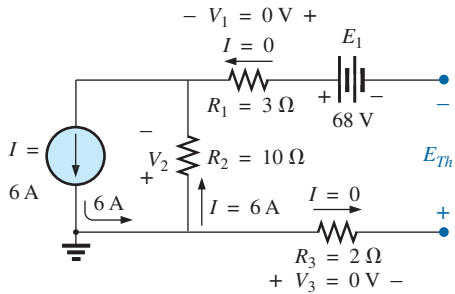

FIG. 9.96

Determining E_{Th} for the network external to resistor R_L in Fig. 9.94.

so that

$$R_L = R_{Th} = 15 \Omega$$

The Thévenin voltage is determined using Fig. 9.96, where

$$V_1 = V_3 = 0 \text{ V} \quad \text{and} \quad V_2 = I_2 R_2 = IR_2 = (6 \text{ A})(10 \Omega) = 60 \text{ V}$$

Applying Kirchhoff's voltage law gives

$$-V_2 - E + E_{Th} = 0$$

and

$$E_{Th} = V_2 + E = 60 \text{ V} + 68 \text{ V} = 128 \text{ V}$$

with the maximum power equal to

$$P_{L_{max}} = \frac{E_{Th}^2}{4R_{Th}} = \frac{(128 \text{ V})^2}{4(15 \Omega)} = 273.07 \text{ W}$$

9.6 MILLMAN'S THEOREM

Through the application of **Millman's theorem**, any number of parallel voltage sources can be reduced to one. In Fig. 9.97, for example, the three voltage sources can be reduced to one. This permits finding the current through or voltage across R_L without having to apply a method such as mesh analysis, nodal analysis, superposition, and so on. The theorem can best be described by applying it to the network in Fig. 9.97. Basically, three steps are included in its application.

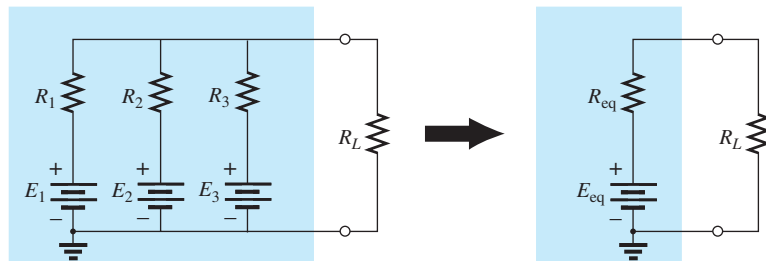

FIG. 9.97

Demonstrating the effect of applying Millman's theorem.

Step 1: Convert all voltage sources to current sources as outlined in Section 8.2. This is performed in Fig. 9.98 for the network in Fig. 9.97.

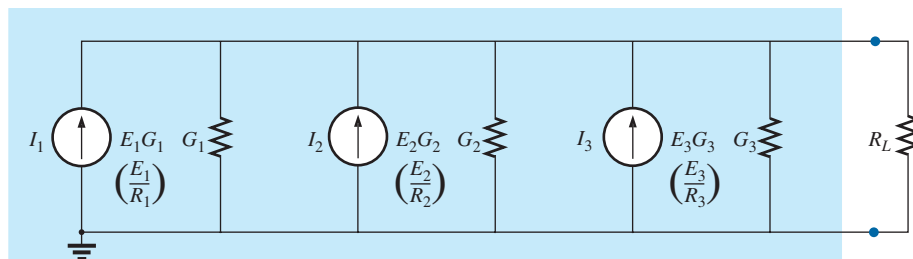

FIG. 9.98

Converting all the sources in Fig. 9.97 to current sources.



Step 2: Combine parallel current sources as described in Section 8.2. The resulting network is shown in Fig. 9.99, where

$$I_T = I_1 + I_2 + I_3 \quad \text{and} \quad G_T = G_1 + G_2 + G_3$$

Step 3: Convert the resulting current source to a voltage source, and the desired single-source network is obtained, as shown in Fig. 9.100.

In general, Millman's theorem states that for any number of parallel voltage sources,

$$E_{\text{eq}} = \frac{I_T}{G_T} = \frac{\pm I_1 \pm I_2 \pm I_3 \pm \cdots \pm I_N}{G_1 + G_2 + G_3 + \cdots + G_N}$$

or

$$E_{\text{eq}} = \frac{\pm E_1 G_1 \pm E_2 G_2 \pm E_3 G_3 \pm \cdots \pm E_N G_N}{G_1 + G_2 + G_3 + \cdots + G_N} \quad (9.8)$$

The plus-and-minus signs appear in Eq. (9.8) to include those cases where the sources may not be supplying energy in the same direction. (Note Example 9.19.)

The equivalent resistance is

$$R_{\text{eq}} = \frac{1}{G_T} = \frac{1}{G_1 + G_2 + G_3 + \cdots + G_N} \quad (9.9)$$

In terms of the resistance values,

$$E_{\text{eq}} = \frac{\pm \frac{E_1}{R_1} \pm \frac{E_2}{R_2} \pm \frac{E_3}{R_3} \pm \cdots \pm \frac{E_N}{R_N}}{\frac{1}{R_1} + \frac{1}{R_2} + \frac{1}{R_3} + \cdots + \frac{1}{R_N}} \quad (9.10)$$

and

$$R_{\text{eq}} = \frac{1}{\frac{1}{R_1} + \frac{1}{R_2} + \frac{1}{R_3} + \cdots + \frac{1}{R_N}} \quad (9.11)$$

Because of the relatively few direct steps required, you may find it easier to apply each step rather than memorizing and employing Eqs. (9.8) through (9.11).

EXAMPLE 9.19 Using Millman's theorem, find the current through and voltage across the resistor R_L in Fig. 9.101.

Solution: By Eq. (9.10),

$$E_{\text{eq}} = \frac{+\frac{E_1}{R_1} - \frac{E_2}{R_2} + \frac{E_3}{R_3}}{\frac{1}{R_1} + \frac{1}{R_2} + \frac{1}{R_3}}$$

The minus sign is used for E_2/R_2 because that supply has the opposite polarity of the other two. The chosen reference direction is therefore that of E_1 and E_3 . The total conductance is unaffected by the direction, and

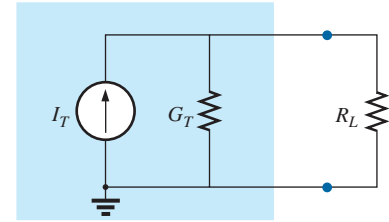

FIG. 9.99

Reducing all the current sources in Fig. 9.98 to a single current source.

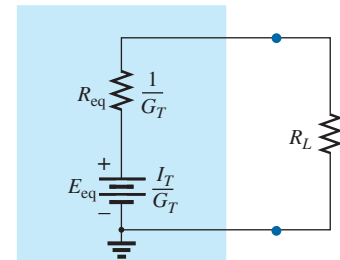

FIG. 9.100

Converting the current source in Fig. 9.99 to a voltage source.

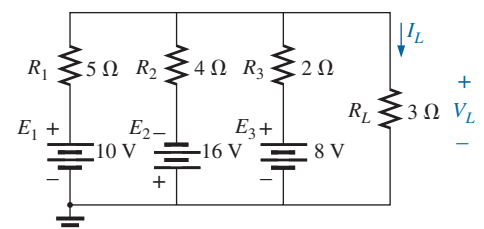

FIG. 9.101

Example 9.19.

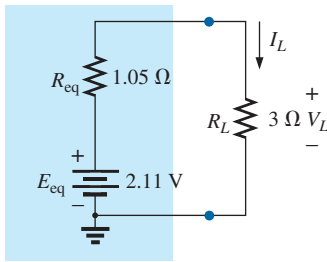

FIG. 9.102

The result of applying Millman's theorem to the network in Fig. 9.101.

$$E_{eq} = \frac{+\frac{10\text{ V}}{5\ \Omega} - \frac{16\text{ V}}{4\ \Omega} + \frac{8\text{ V}}{2\ \Omega}}{\frac{1}{5\ \Omega} + \frac{1}{4\ \Omega} + \frac{1}{2\ \Omega}} = \frac{2\text{ A} - 4\text{ A} + 4\text{ A}}{0.2\text{ S} + 0.25\text{ S} + 0.5\text{ S}}$$

$$= \frac{2\text{ A}}{0.95\text{ S}} = \mathbf{2.11\text{ V}}$$

with $R_{eq} = \frac{1}{\frac{1}{5\ \Omega} + \frac{1}{4\ \Omega} + \frac{1}{2\ \Omega}} = \frac{1}{0.95\text{ S}} = \mathbf{1.05\ \Omega}$

The resultant source is shown in Fig. 9.102, and

$$I_L = \frac{2.11\text{ V}}{1.05\ \Omega + 3\ \Omega} = \frac{2.11\text{ V}}{4.05\ \Omega} = \mathbf{0.52\text{ A}}$$

with $V_L = I_L R_L = (0.52\text{ A})(3\ \Omega) = \mathbf{1.56\text{ V}}$

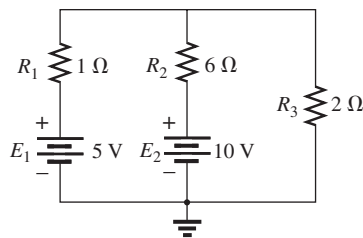

FIG. 9.103

Example 9.20.

EXAMPLE 9.20 Let us now consider the type of problem encountered in the introduction to mesh and nodal analysis in Chapter 8. Mesh analysis was applied to the network of Fig. 9.103 (Example 8.14). Let us now use Millman's theorem to find the current through the 2 Ω resistor and compare the results.

Solutions:

- a. Let us first apply each step and, in the (b) solution, Eq. (9.10). Converting sources yields Fig. 9.104. Combining sources and parallel conductance branches (Fig. 9.105) yields

$$I_T = I_1 + I_2 = 5\text{ A} + \frac{5}{3}\text{ A} = \frac{15}{3}\text{ A} + \frac{5}{3}\text{ A} = \frac{20}{3}\text{ A}$$

$$G_T = G_1 + G_2 = 1\text{ S} + \frac{1}{6}\text{ S} = \frac{6}{6}\text{ S} + \frac{1}{6}\text{ S} = \frac{7}{6}\text{ S}$$

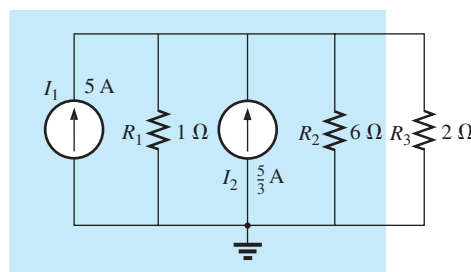

FIG. 9.104

Converting the sources in Fig. 9.103 to current sources.

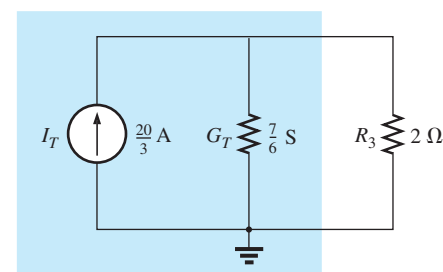

FIG. 9.105

Reducing the current sources in Fig. 9.104 to a single source.

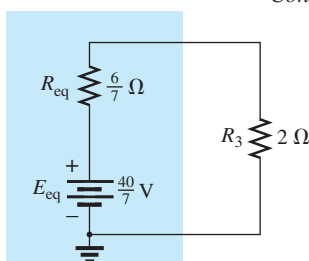

FIG. 9.106

Converting the current source in Fig. 9.105 to a voltage source.

Converting the current source to a voltage source (Fig. 9.106), we obtain

$$E_{eq} = \frac{I_T}{G_T} = \frac{\frac{20}{3}\text{ A}}{\frac{7}{6}\text{ S}} = \frac{(6)(20)}{(3)(7)}\text{ V} = \mathbf{\frac{40}{7}\text{ V}}$$

and $R_{eq} = \frac{1}{G_T} = \frac{1}{\frac{7}{6}\text{ S}} = \mathbf{\frac{6}{7}\ \Omega}$



so that

$$I_{2\Omega} = \frac{E_{\text{eq}}}{R_{\text{eq}} + R_3} = \frac{\frac{40}{7} \text{ V}}{\frac{6}{7} \Omega + 2 \Omega} = \frac{\frac{40}{7} \text{ V}}{\frac{6}{7} \Omega + \frac{14}{7} \Omega} = \frac{40 \text{ V}}{20 \Omega} = 2 \text{ A}$$

which agrees with the result obtained in Example 8.14.

b. Let us now simply apply the proper equation, Eq. (9.10):

$$E_{\text{eq}} = \frac{+\frac{5 \text{ V}}{1 \Omega} + \frac{10 \text{ V}}{6 \Omega}}{\frac{1}{1 \Omega} + \frac{1}{6 \Omega}} = \frac{\frac{30 \text{ V}}{6 \Omega} + \frac{10 \text{ V}}{6 \Omega}}{\frac{6}{6 \Omega} + \frac{1}{6 \Omega}} = \frac{40}{7} \text{ V}$$

and

$$R_{\text{eq}} = \frac{1}{\frac{1}{1 \Omega} + \frac{1}{6 \Omega}} = \frac{1}{\frac{6}{6 \Omega} + \frac{1}{6 \Omega}} = \frac{1}{\frac{7}{6}} = \frac{6}{7} \Omega$$

which are the same values obtained above.

The dual of Millman's theorem (Fig. 9.97) appears in Fig. 9.107. It can be shown that I_{eq} and R_{eq} , as in Fig. 9.107, are given by

$$I_{\text{eq}} = \frac{\pm I_1 R_1 \pm I_2 R_2 \pm I_3 R_3}{R_1 + R_2 + R_3} \quad (9.12)$$

and

$$R_{\text{eq}} = R_1 + R_2 + R_3 \quad (9.13)$$

The derivation appears as a problem at the end of the chapter.

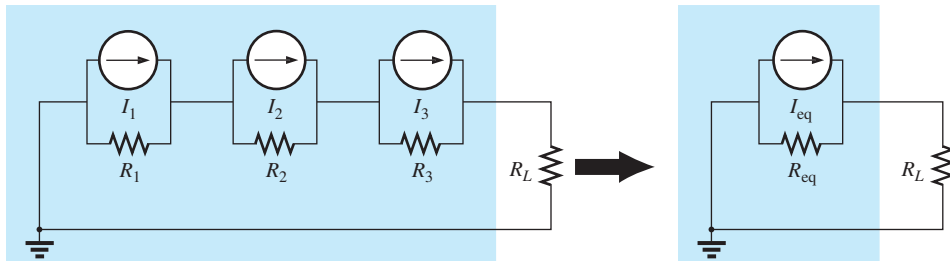

FIG. 9.107

The dual effect of Millman's theorem.

9.7 SUBSTITUTION THEOREM

The **substitution theorem** states the following:

If the voltage across and the current through any branch of a dc bilateral network are known, this branch can be replaced by any combination of elements that will maintain the same voltage across and current through the chosen branch.

More simply, the theorem states that for branch equivalence, the terminal voltage and current must be the same. Consider the circuit in Fig. 9.108, in which the voltage across and current through the branch

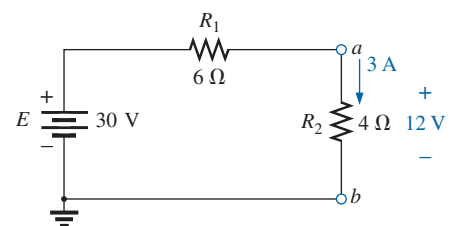

FIG. 9.108

Demonstrating the effect of the substitution theorem.

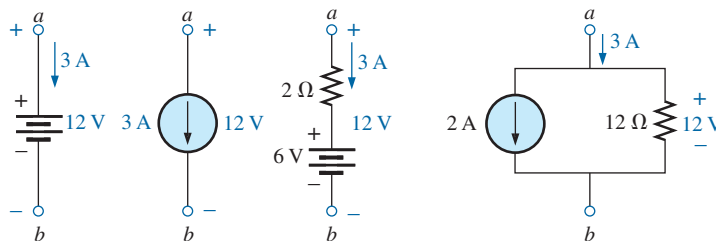

FIG. 9.109

Equivalent branches for the branch $a-b$ in Fig. 9.108.

$a-b$ are determined. Through the use of the substitution theorem, a number of equivalent $a-a'$ branches are shown in Fig. 9.109.

Note that for each equivalent, the terminal voltage and current are the same. Also consider that the response of the remainder of the circuit in Fig. 9.108 is unchanged by substituting any one of the equivalent branches. As demonstrated by the single-source equivalents in Fig. 9.109, a known potential difference and current in a network can be replaced by an ideal voltage source and current source, respectively.

Understand that this theorem cannot be used to solve networks with two or more sources that are not in series or parallel. For it to be applied, a potential difference or current value must be known or found using one of the techniques discussed earlier. One application of the theorem is shown in Fig. 9.110. Note that in the figure the known potential difference V was replaced by a voltage source, permitting the isolation of the portion of the network including R_3 , R_4 , and R_5 . Recall that this was basically the approach used in the analysis of the ladder network as we worked our way back toward the terminal resistance R_5 .

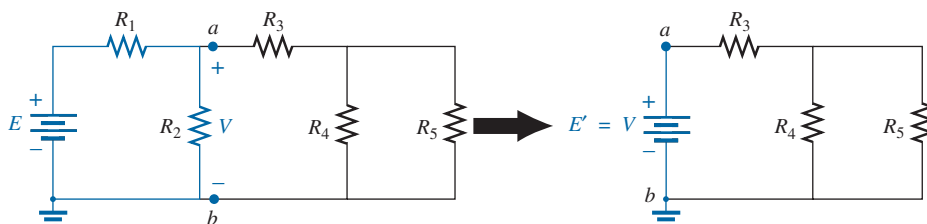

FIG. 9.110

Demonstrating the effect of knowing a voltage at some point in a complex network.

The current source equivalence of the above is shown in Fig. 9.111, where a known current is replaced by an ideal current source, permitting the isolation of R_4 and R_5 .

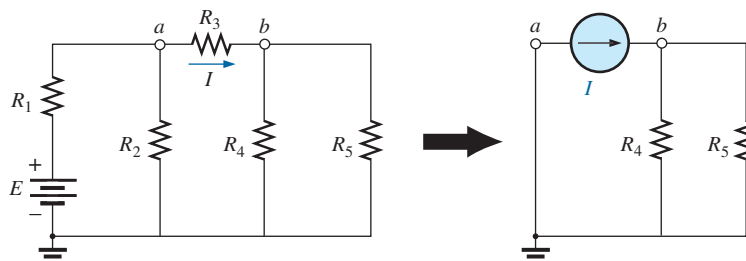

FIG. 9.111

Demonstrating the effect of knowing a current at some point in a complex network.

Recall from the discussion of bridge networks that $V = 0$ and $I = 0$ were replaced by a short circuit and an open circuit, respectively. This substitution is a very specific application of the substitution theorem.

9.8 RECIPROCITY THEOREM

The **reciprocity theorem** is applicable only to single-source networks. It is, therefore, not a theorem used in the analysis of multisource networks described thus far. The theorem states the following:

The current I in any branch of a network due to a single voltage source E anywhere else in the network will equal the current through the branch in which the source was originally located if the source is placed in the branch in which the current I was originally measured.

In other words, the location of the voltage source and the resulting current may be interchanged without a change in current. The theorem requires that the polarity of the voltage source have the same correspondence with the direction of the branch current in each position.

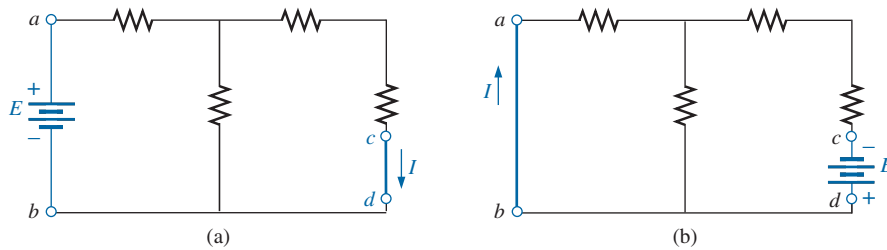

FIG. 9.112

Demonstrating the impact of the reciprocity theorem.

In the representative network in Fig. 9.112(a), the current I due to the voltage source E was determined. If the position of each is interchanged as shown in Fig. 9.112(b), the current I will be the same value as indicated. To demonstrate the validity of this statement and the theorem, consider the network in Fig. 9.113, in which values for the elements of Fig. 9.112(a) have been assigned.

The total resistance is

$$R_T = R_1 + R_2 \parallel (R_3 + R_4) = 12 \Omega + 6 \Omega \parallel (2 \Omega + 4 \Omega) \\ = 12 \Omega + 6 \Omega \parallel 6 \Omega = 12 \Omega + 3 \Omega = 15 \Omega$$

and
$$I_s = \frac{E}{R_T} = \frac{45 \text{ V}}{15 \Omega} = 3 \text{ A}$$

with
$$I = \frac{3 \text{ A}}{2} = 1.5 \text{ A}$$

For the network in Fig. 9.114, which corresponds to that in Fig. 9.112(b), we find

$$R_T = R_4 + R_3 + R_1 \parallel R_2 \\ = 4 \Omega + 2 \Omega + 12 \Omega \parallel 6 \Omega = 10 \Omega$$

and
$$I_s = \frac{E}{R_T} = \frac{45 \text{ V}}{10 \Omega} = 4.5 \text{ A}$$

so that
$$I = \frac{(6 \Omega)(4.5 \text{ A})}{12 \Omega + 6 \Omega} = \frac{4.5 \text{ A}}{3} = 1.5 \text{ A}$$

which agrees with the above.

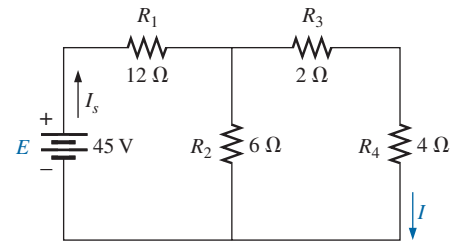

FIG. 9.113

Finding the current I due to a source E .

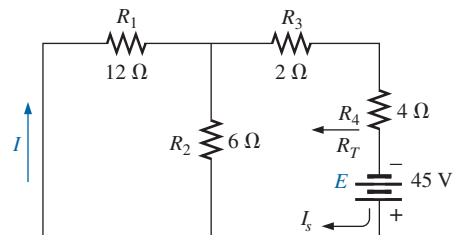

FIG. 9.114

Interchanging the location of E and I of Fig. 9.113 to demonstrate the validity of the reciprocity theorem.



The uniqueness and power of this theorem can best be demonstrated by considering a complex, single-source network such as the one shown in Fig. 9.115.

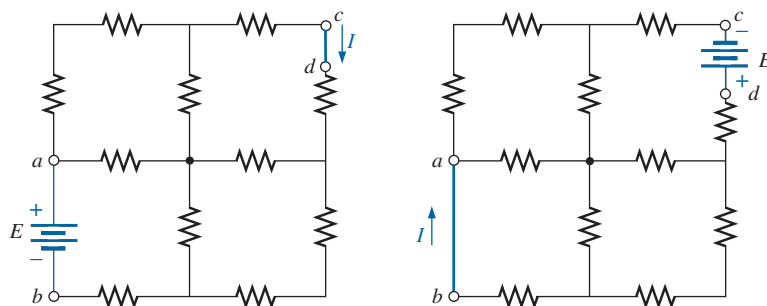

FIG. 9.115

Demonstrating the power and uniqueness of the reciprocity theorem.

9.9 COMPUTER ANALYSIS

Once you understand the mechanics of applying a software package or language, the opportunity to be creative and innovative presents itself. Through years of exposure and trial-and-error experiences, professional programmers develop a catalog of innovative techniques that are not only functional but very interesting and truly artistic in nature. Now that some of the basic operations associated with PSpice have been introduced, a few innovative maneuvers will be made in the examples to follow.

PSpice

Thévenin's Theorem The application of Thévenin's theorem requires an interesting maneuver to determine the Thévenin resistance. It is a maneuver, however, that has application beyond Thévenin's theorem whenever a resistance level is required. The network to be analyzed appears in Fig. 9.116 and is the same one analyzed in Example 9.10 (Fig. 9.48).

Since PSpice is not set up to measure resistance levels directly, a 1 A current source can be applied as shown in Fig. 9.117, and Ohm's law can be used to determine the magnitude of the Thévenin resistance in the following manner:

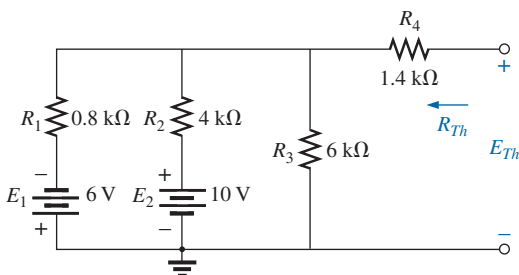

FIG. 9.116

Network to which PSpice is to be applied to determine E_{Th} and R_{Th} .

$$|R_{Th}| = \left| \frac{V_s}{I_s} \right| = \left| \frac{V_s}{1 \text{ A}} \right| = |V_s| \tag{9.14}$$

In Eq. (9.14), since $I_s = 1\text{A}$, the magnitude of R_{Th} in ohms is the same as the magnitude of the voltage V_s (in volts) across the current source. The result is that when the voltage across the current source is displayed, it can be read as ohms rather than volts.

When PSpice is applied, the network appears as shown in Fig. 9.117. Flip the voltage source E_1 and the current source by right-clicking on the source and choosing the **Mirror Vertically** option. Set both voltage sources to zero through the **Display Properties** dialog box obtained by double-clicking on the source symbol. The result of the **Bias Point** simulation is 2 kV across the current source. The Thévenin resistance is therefore 2 kΩ between the two terminals of the network to the left of the current source (to match the results of Example 9.10). In total, by

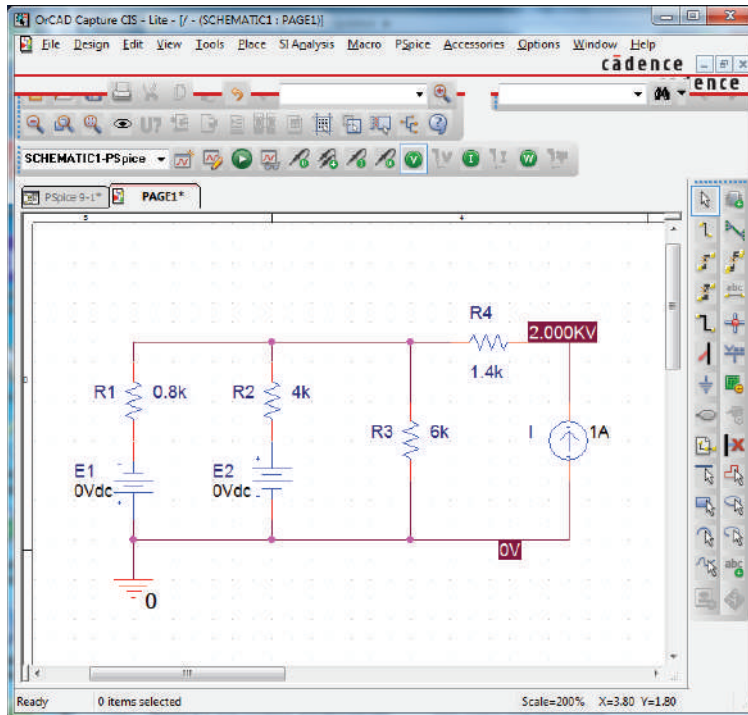
FIG. 9.117

Using PSpice to determine the Thévenin resistance of a network through the application of a 1 A current source.

setting the voltage source to 0 V, we have dictated that the voltage is the same at both ends of the voltage source, replicating the effect of a short-circuit connection between the two points.

For the open-circuit Thévenin voltage between the terminals of interest, the network must be constructed as shown in Fig. 9.118. The resistance of 1 T (= 1 million $M\Omega$) is considered large enough to represent an open circuit to permit an analysis of the network using PSpice. PSpice does not recognize floating nodes and generates an error signal if a connection is not made from the top right node to ground. Both voltage sources are now set on their prescribed values, and a simulation results in 3 V across the 1 T resistor. The open-circuit Thévenin voltage is therefore 3 V, which agrees with the solution in Example 9.10.

Maximum Power Transfer The procedure for plotting a quantity versus a parameter of the network is now introduced. In this case, the output power versus values of load resistance is used to verify that maximum power is delivered to the load when its value equals the series Thévenin resistance. A number of new steps are introduced, but keep in mind that the method has broad application beyond Thévenin's theorem and is therefore well worth the learning process.

The circuit to be analyzed appears in Fig. 9.119. The circuit is constructed in exactly the same manner as described earlier except for the value of the load resistance. Begin the process by starting a **New Project** labeled **PSpice 9-3**, and build the circuit in Fig. 9.119. For the moment, do not set the value of the load resistance.

The first step is to establish the value of the load resistance as a variable since it will not be assigned a fixed value. Double-click on the value of **RL**, which is initially 1 k Ω , to obtain the **Display Properties** dialog

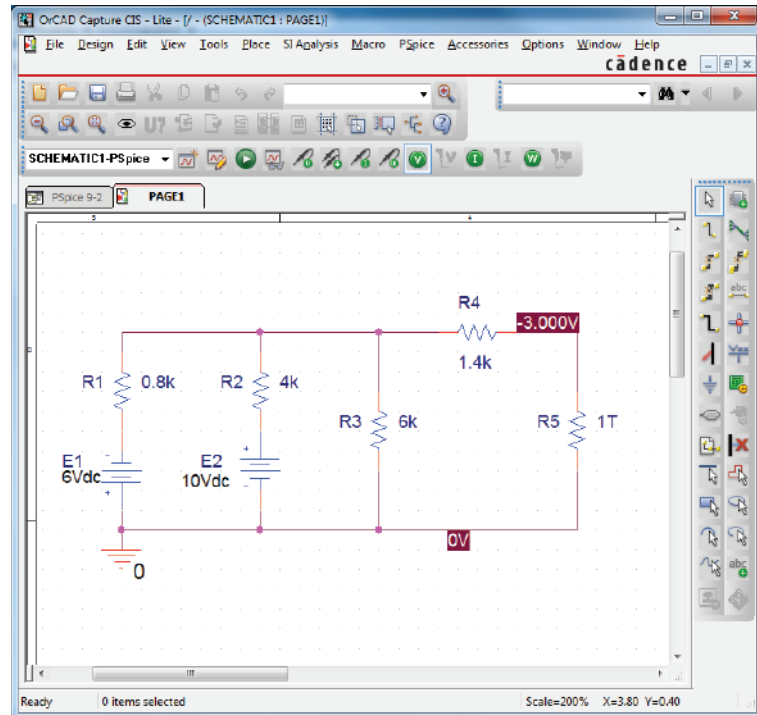
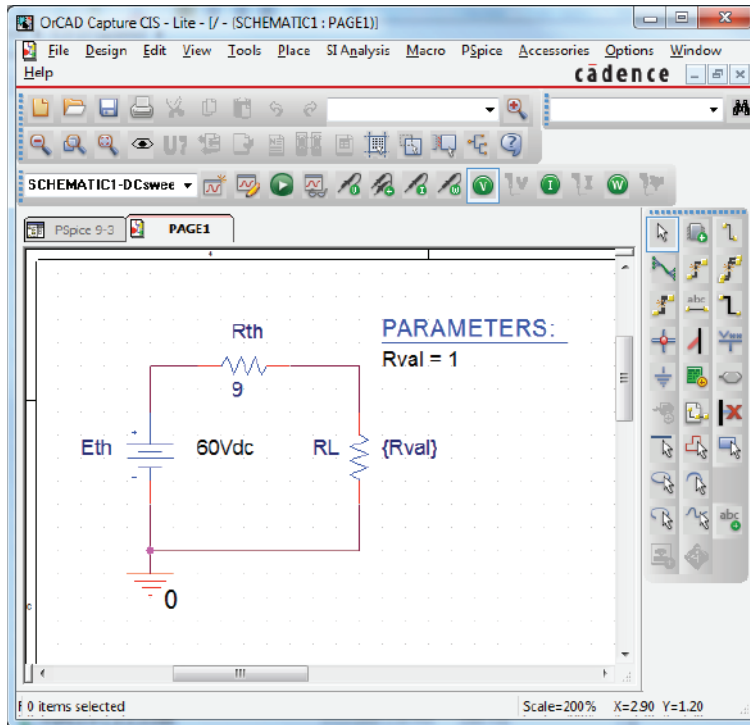

FIG. 9.118

Using PSpice to determine the Thévenin voltage for a network using a very large resistance value to represent the open-circuit condition between the terminals of interest.

box. For **Value**, type in {**Rval**} and click in place. The brackets (*not* parentheses) are required, but the variable does not have to be called **Rval**—it is the choice of the user. Next select the **Place part** key to obtain the **Place Part** dialog box. If you are not already in the **Libraries** list, choose **Add Library** and add **SPECIAL** to the list. Select the **SPECIAL** library and scroll the **Part List** until **PARAM** appears. Select and then **Place Part** to obtain a rectangular box next to the cursor on the screen. Select a spot near **Rval**, and deposit the rectangle. The result is **PARAMETERS:** as shown in Fig. 9.119.

Next double-click on **PARAMETERS:** to obtain a **Property Editor** dialog box, which should have **SCHEMATIC1:PAGE1** in the second column from the left. Now select the **New Property** option from the top list of choices. An **Undo Warning !!** dialog box will appear. Select **Yes** to continue. An **Add New Property** dialog box will appear in which the **Name:** is entered as **Rval** and the **Value:** as **1**. Then **OK** and the **Undo Warning !!** dialog box will appear again (to really be sure you want to do it!) and the **Yes** selected again. If you now move the position control at the bottom of the screen to the left (only slightly) you will see **Rval/1** as a new column in the **SCHEMATIC1:PAGE1** listing. Now select **Rval/1** by clicking on **Rval** to surround **Rval** by a dashed line and add a black background around the **1**. Choose **Display** to produce the **Display Properties** dialog box, and select **Name and Value** followed by **OK**. Then exit the **Property Editor** dialog box by selecting **PAGE1*** in the row above the schematic to display the screen in Fig. 9.119. Note that now the first value (1 Ω) of **Rval** is displayed.

FIG. 9.119

Using PSpice to plot the power to R_L for a range of values for R_L .

We are now ready to set up the simulation process. Select the **New Simulation Profile** key to open the **New Simulation** dialog box. Enter **DC Sweep** under **Name** followed by **Create**. A blinking **Simulation Setting-Rval** dialog box will then appear at the bottom of the screen that can be selected so it will appear in full size on the screen. After selecting **Analysis**, select **DC Sweep** under the **Analysis type** heading. Then leave the **Primary Sweep** under the **Options** heading, and select **Global parameter** under the **Sweep variable**. The **Parameter name** should then be entered as **Rval**. For the **Sweep type**, the **Start value** should be $1\ \Omega$; but if we use $1\ \Omega$, the curve to be generated will start at $1\ \Omega$, leaving a blank from 0 to $1\ \Omega$. The curve will look incomplete. To solve this problem, select $0.001\ \Omega$ as the **Start value** (very close to $0\ \Omega$) with an **Increment** of $0.001\ \Omega$. Enter the **End value** as $31\ \Omega$ to ensure a calculation at $R_L = 30.001\ \Omega$. If we used $30\ \Omega$ as the end value, the last calculation would be at $29.001\ \Omega$ since $29.001\ \Omega + 1\ \Omega = 30.001\ \Omega$, which is beyond the range of $30\ \Omega$. The values of **RL** will therefore be $0.001\ \Omega$, $1.001\ \Omega$, $2.001\ \Omega$, . . . $29.001\ \Omega$, $30.001\ \Omega$, and so on, although the plot will look as if the values were $0\ \Omega$, $1\ \Omega$, $2\ \Omega$, $29\ \Omega$, $30\ \Omega$, and so on. Click **OK**, and select the **Run PSpice** key, which will activate the analysis and result in a blinking yellow screen at the bottom of the window. Select and the plot will appear as shown in Fig. 9.120.

Note that there are no plots on the graph, and that the graph extends to $40\ \Omega$ rather than $30\ \Omega$ as desired. It did not respond with a plot of power versus **RL** because we have not defined the plot of interest for the computer. To do this, select the **Add Trace** key (the key that has a red curve peaking in the middle of the plot) or **Trace-Add Trace** from the top menu bar. Either choice results in the **Add Traces** dialog box.

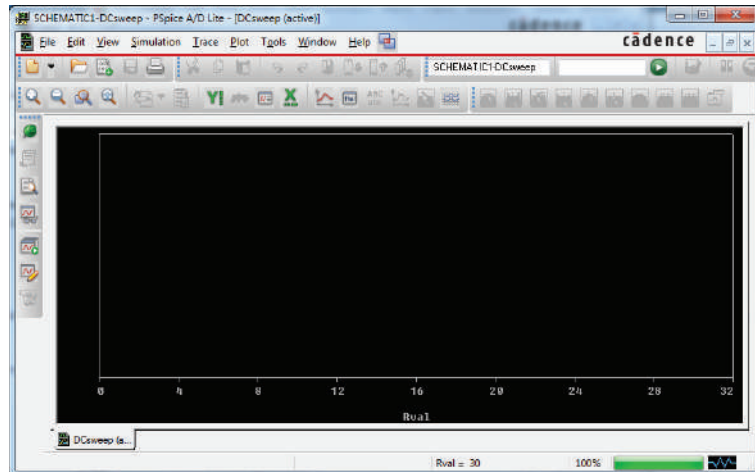

FIG. 9.120

Plot resulting from the dc sweep of R_L for the network in Fig. 9.119 before defining the parameters to be displayed.

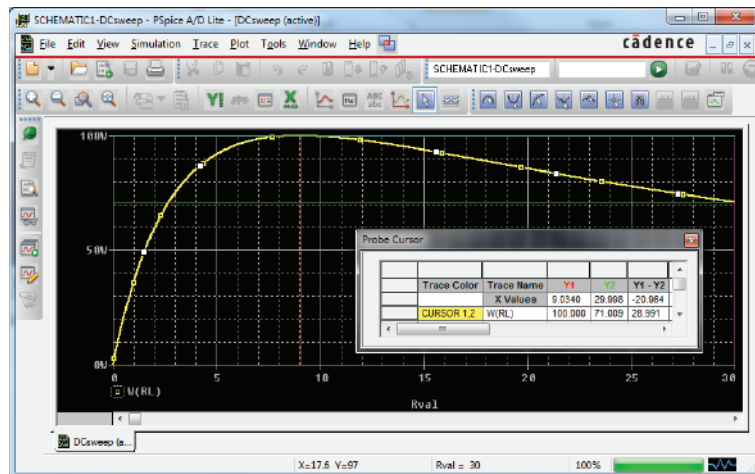

FIG. 9.121

A plot of the power delivered to R_L in Fig. 9.119 for a range of values for R_L extending from $0\ \Omega$ to $30\ \Omega$.

The most important region of this dialog box is the **Trace Expression** listing at the bottom. The desired trace can be typed in directly, or the quantities of interest can be chosen from the list of **Simulation Output Variables** and deposited in the **Trace Expression** listing. To find the power to **RL** for the chosen range of values for **RL**, select **W(RL)** in the listing; it then appears as the **Trace Expression**. Click **OK**, and the plot in Fig. 9.121 appears. Originally, the plot extended from $0\ \Omega$ to $40\ \Omega$. We reduced the range to $0\ \Omega$ to $31\ \Omega$ by selecting **Plot-Axis Settings-X Axis-User Defined 0 to 31-OK**.

Select the **Toggle cursor** key (which has an arrow set in a blue background) at the top of the dialog box and seven options will open to the right of the key that include **Cursor Peak**, **Cursor Trough**, **Cursor Slope**, **Cursor Min**, **Cursor Max**, **Cursor Point**, and **Cursor Search**. Select **Cursor Max** (the fifth one over), and the **Probe Cursor** dialog box on the screen will reveal where the peak occurred and the power



level at that point. In the **Probe Cursor** dialog box the first column titled **Trace Color** reveals the color of the trace on the **W(RL)** plot. This becomes important when there is more than one trace on the screen. The next column titled **Trace Name** is labeled **X** values and gives the location on the horizontal axis for the point of interest **Y1**. Note that it is approximately $9\ \Omega$ to match the point of maximum power to the load **RL**. The next line reveals that the power **W(RL)** is 100W at $R_L = 9\ \Omega$. There are other options available in the **Probe Cursor** dialog box by scrolling to the right.

It is possible that the **Probe Cursor** box will not appear as a separate entity on the screen but simply as an attachment at the bottom of the response screen. It can be isolated by deleting the dialog boxes to the right and left and then right-clicking the **Toggle Cursor** key. By simply unchecking the **Allow Docking** option the **Probe Cursor** dialog box will appear as a separate entity as obtained above. It can then be moved to any location on the screen. A second cursor can be generated by right-clicking the mouse on the **Cursor Point** option and moving it to a resistance of $30\ \Omega$. The result is a power level of 71.009W , as shown on the plot. Notice also that the plot generated appears as a listing at the bottom left of the screen as **W(RL)**.

Multisim

Superposition Let us now apply superposition to the network in Fig. 9.122, which appeared earlier as Fig. 9.2 in Example 9.1, to permit a comparison of resulting solutions. The current through R_2 is to be determined. With the use of methods described in earlier chapters for the application of Multisim, the network in Fig. 9.123 results, which

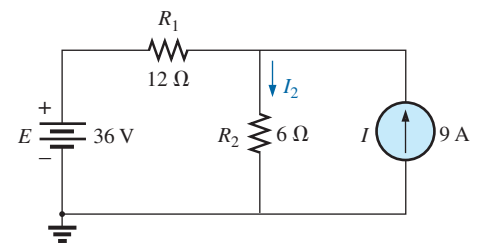

FIG. 9.122

Applying Multisim to determine the current I_2 using superposition.

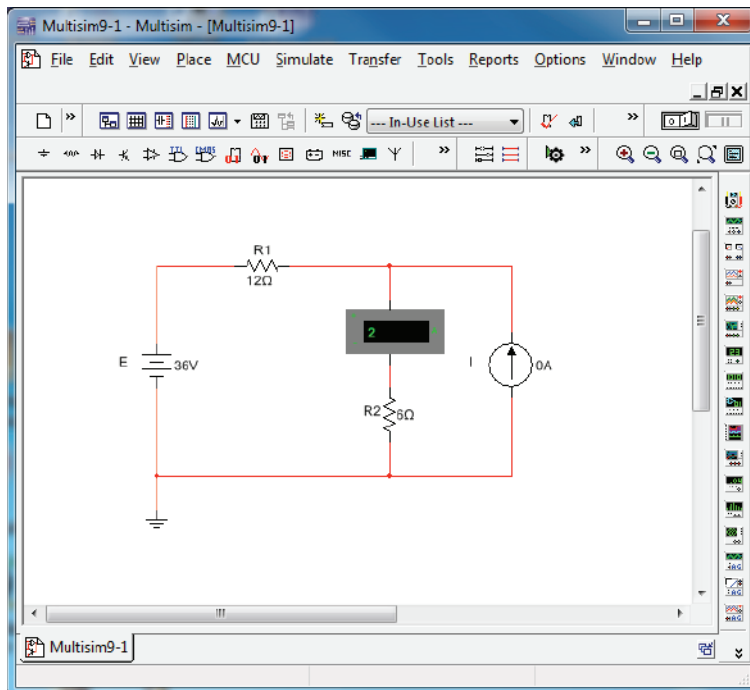

FIG. 9.123

Using Multisim to determine the contribution of the 36 V voltage source to the current through R_2 .



allows us to determine the effect of the 36 V voltage source. Note in Fig. 9.123 that both the voltage source and current source are present even though we are finding the contribution due solely to the voltage source. Obtain the voltage source by selecting the **Place Source** option at the top of the left toolbar to open the **Select a Component** dialog box. Then select **POWER_SOURCES** followed by **DC_POWER** as described in earlier chapters. You can also obtain the current source from the same dialog box by selecting **SIGNAL_CURRENT** under **Family** followed by **DC_CURRENT** under **Component**. The current source can be flipped vertically by right-clicking the source and selecting **Flip Vertical**. Set the current source to zero by left-clicking the source twice to obtain the **DC_CURRENT** dialog box. After choosing **Value**, set **Current(I)** to 0 A.

Following simulation, the results appear as in Fig. 9.123. The current through the $6\ \Omega$ resistor is 2 A due solely to the 36 V voltage source. The positive value for the 2 A reading reveals that the current due to the 36 V source is down through resistor R_2 .

For the effects of the current source, the voltage source is set to 0 V as shown in Fig. 9.124. The resulting current is then 6 A through R_2 , with the same direction as the contribution due to the voltage source.

The resulting current for the resistor R_2 is the sum of the two currents: $I_T = 2\ \text{A} + 6\ \text{A} = 8\ \text{A}$, as determined in Example 9.1.

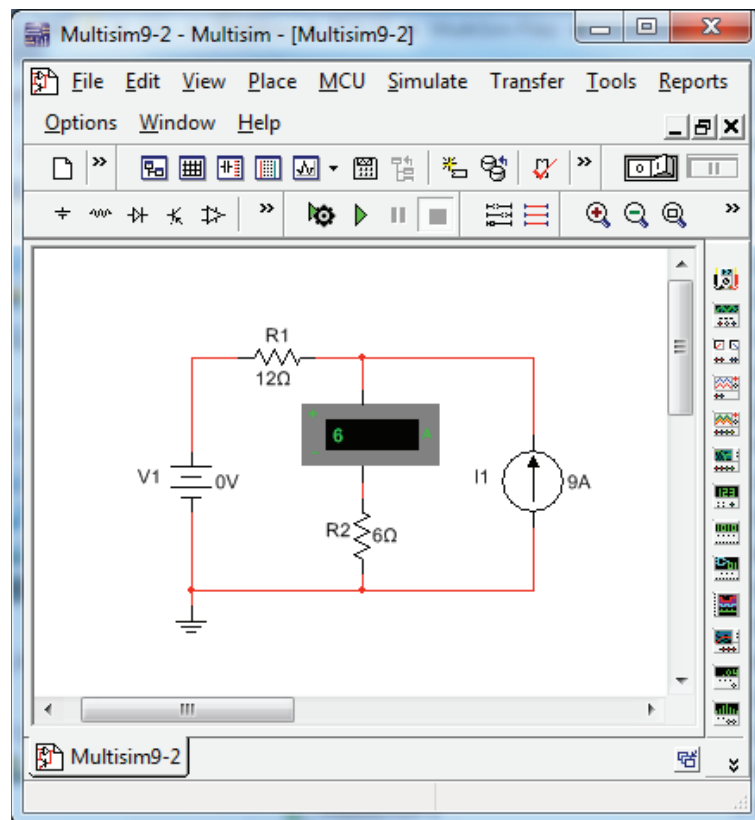

FIG. 9.124

Using Multisim to determine the contribution of the 9 A current source to the current through R_2 .



PROBLEMS

SECTION 9.2 Superposition Theorem

- Using the superposition theorem, determine the current through the $12\ \Omega$ resistor of Fig. 9.125.
 - Convert both voltage sources to current sources and recalculate the current to the $12\ \Omega$ resistor.
 - How do the results of parts (a) and (b) compare?

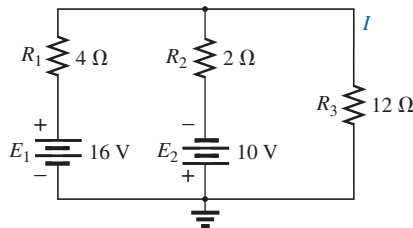

FIG. 9.125
Problem 1.

- Using the superposition theorem, determine the voltage across the $4.7\ \Omega$ resistor of Fig. 9.126.
 - Find the power delivered to the $4.7\ \Omega$ resistor due solely to the current source.
 - Find the power delivered to the $4.7\ \Omega$ resistor due solely to the voltage source.
 - Find the power delivered to the $4.7\ \Omega$ resistor using the voltage found in part (a).
 - How do the results of part (d) compare with the sum of the results to parts (b) and (c)? Can the superposition theorem be applied to power levels?

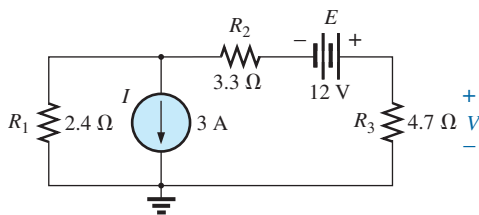

FIG. 9.126
Problem 2.

- Using the superposition theorem, determine the current through the $56\ \Omega$ resistor of Fig. 9.127.

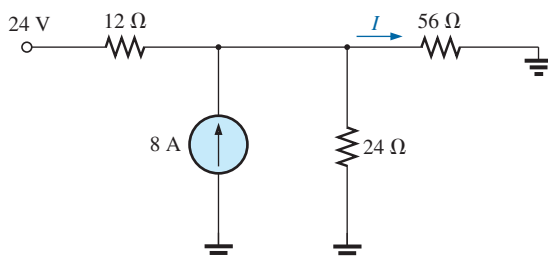

FIG. 9.127
Problem 3.

- Using superposition, find the current I through the $24\ \text{V}$ source in Fig. 9.128.

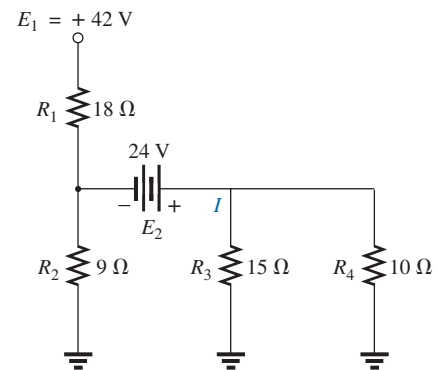

FIG. 9.128
Problem 4.

- Using superposition, find the voltage V_{R_3} for the network of Fig. 9.129.

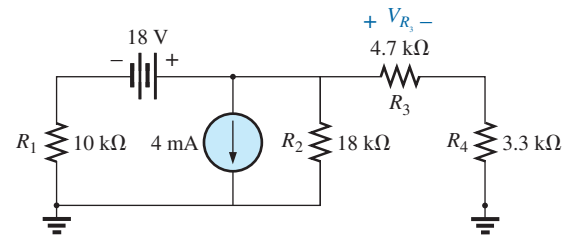

FIG. 9.129
Problem 5.

- Using superposition, find the voltage V_2 for the network in Fig. 9.130.

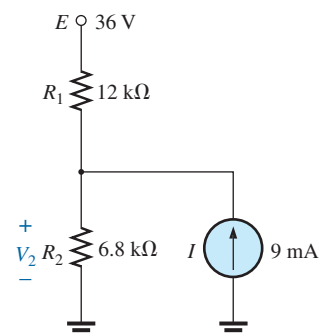

FIG. 9.130
Problem 6.



- *7. Using superposition, find the current through R_1 for the network in Fig. 9.131.

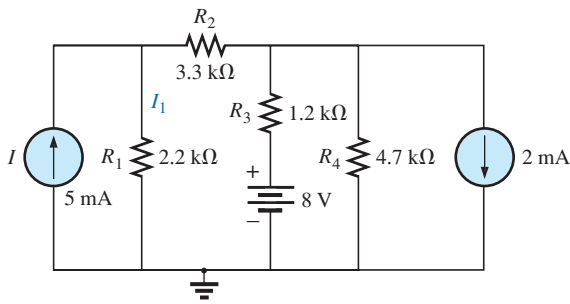

FIG. 9.131
Problem 7.

- *8. Using superposition, find the voltage across the 6 A source in Fig. 9.132.

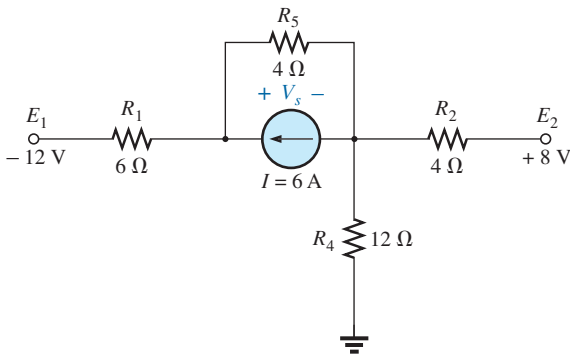

FIG. 9.132
Problem 8.

SECTION 9.3 Thévenin's Theorem

9. a. Find the Thévenin equivalent circuit for the network external to the resistor R in Fig. 9.133.
 b. Find the current through R when R is 2 Ω, 30 Ω, and 100 Ω.

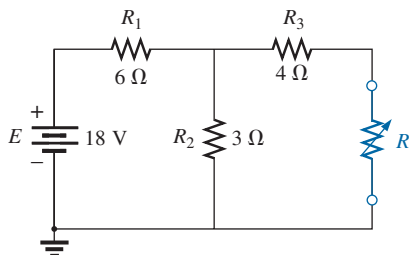

FIG. 9.133
Problem 9.

10. a. Find the Thévenin equivalent circuit for the network external to the resistor R for the network in Fig. 9.134.
 b. Find the power delivered to R when R is 2 kΩ and 100 kΩ.

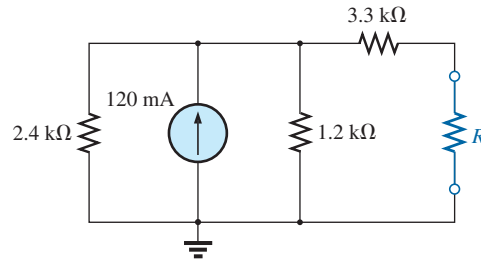

FIG. 9.134
Problem 10.

11. a. Find the Thévenin equivalent circuit for the network external to the resistor R for the network in Fig. 9.135.
 b. Find the power delivered to R when R is 2 Ω and 100 Ω.

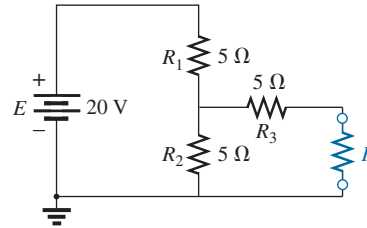

FIG. 9.135
Problem 11.

12. Find the Thévenin equivalent circuit for the network external to the resistor R for the network in Fig. 9.136.

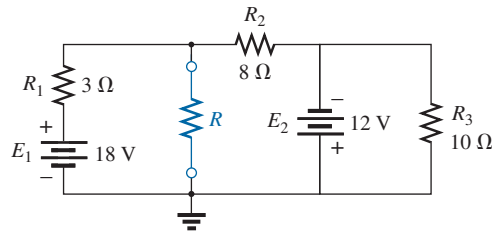

FIG. 9.136
Problem 12.

13. Find the Thévenin equivalent circuit for the network external to the resistor R for the network in Fig. 9.137.

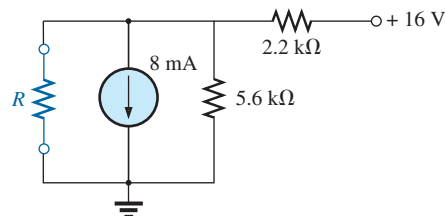

FIG. 9.137
Problem 13.



- *14. Find the Thévenin equivalent circuit for the network external to the resistor R in Fig. 9.138.

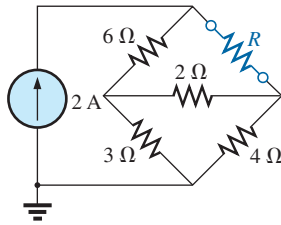

FIG. 9.138
Problem 14.

15. a. Find the Thévenin equivalent circuit for the portions of the network of Fig. 9.139 external to points a and b .
b. Redraw the network with the Thévenin circuit in place and find the current through the $10\text{ k}\Omega$ resistor.

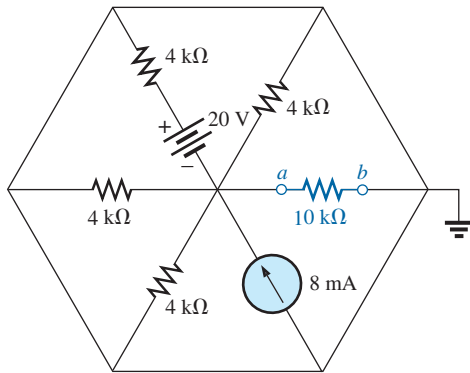

FIG. 9.139
Problem 15.

- *16. a. Determine the Thévenin equivalent circuit for the network external to the resistor R in Fig. 9.140.
b. Find the current through the resistor R if its value is $20\ \Omega$, $50\ \Omega$, and $100\ \Omega$.
c. Without having the Thévenin equivalent circuit, what would you have to do to find the current through the resistor R for all the values of part (b)?

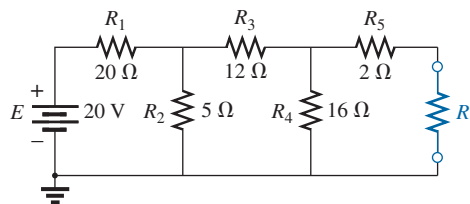

FIG. 9.140
Problem 16.

- *17. a. Determine the Thévenin equivalent circuit for the network external to the resistor R in Fig. 9.141.
b. Find the polarity and magnitude of the voltage across the resistor R if its value is $1.2\text{ k}\Omega$.

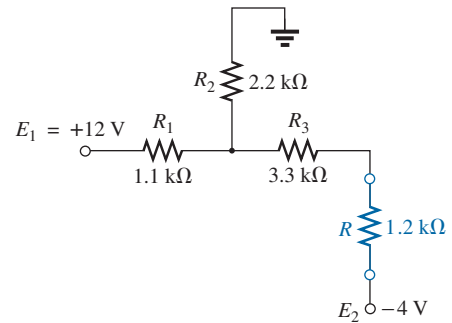

FIG. 9.141
Problem 17.

- *18. For the network in Fig. 9.142, find the Thévenin equivalent circuit for the network external to the load resistor R_L .

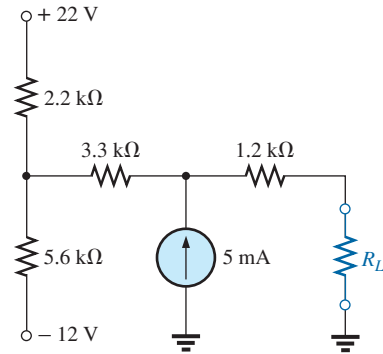

FIG. 9.142
Problem 18.

- *19. For the transistor network in Fig. 9.143:
a. Find the Thévenin equivalent circuit for that portion of the network to the left of the base (B) terminal.
b. Using the fact that $I_C = I_E$ and $V_{CE} = 8\text{ V}$, determine the magnitude of I_E .
c. Using the results of parts (a) and (b), calculate the base current I_B if $V_{BE} = 0.7\text{ V}$.
d. What is the voltage V_C ?

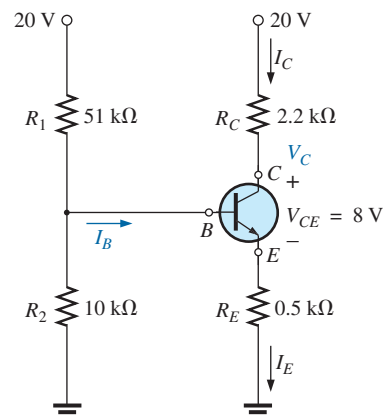

FIG. 9.143
Problem 19.



20. For each vertical set of measurements appearing in Fig. 9.144, determine the Thévenin equivalent circuit.

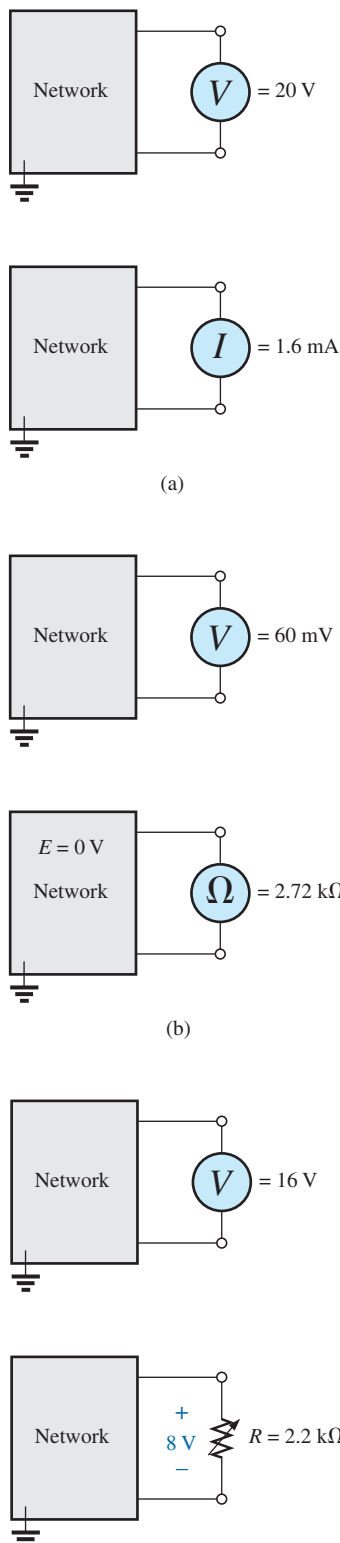

FIG. 9.144
Problem 20.

*21. For the network of Fig. 9.145, find the Thévenin equivalent circuit for the network external to the 300 Ω resistor.

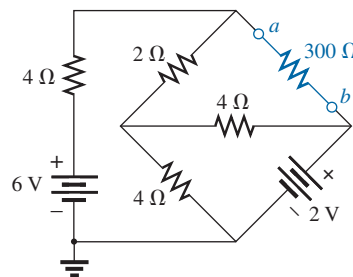

FIG. 9.145
Problem 21.

SECTION 9.4 Norton's Theorem

- 22. a. Find the Norton equivalent circuit for the network external to the resistor R in Fig. 9.133.
- b. Convert the Norton equivalent circuit to the Thévenin form.
- c. Find the Thévenin equivalent circuit using the Thévenin approach and compare results with part (b).
- 23. a. Find the Norton equivalent circuit for the network external to the resistor R in Fig. 9.134.
- b. Convert the Norton equivalent circuit to the Thévenin form.
- c. Find the Thévenin equivalent circuit using the Thévenin approach and compare results with part (b).
- 24. Find the Norton equivalent circuit for the network external to the resistor R in Fig. 9.136.
- 25. Find the Norton equivalent circuit for the network external to the resistor R in Fig. 9.137.
- *26. Find the Norton equivalent circuit for the network external to the resistor R in Fig. 9.138.
- *27. Find the Norton equivalent circuit for the network external to the resistor R in Fig. 9.140.
- *28. Find the Norton equivalent circuit for the network external to the resistor R_L in Fig. 9.142.
- *29. Find the Norton equivalent circuit for the network external to the 300 Ω resistor in Fig. 9.145.
- *30. a. Find the Norton equivalent circuit external to points a and b in Fig. 9.146.
- b. Find the magnitude and polarity of the voltage across the 100 Ω resistor using the results of part (a).

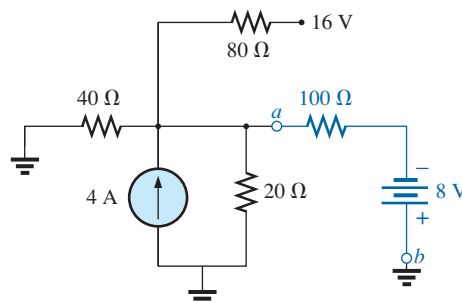

FIG. 9.146
Problem 30.

SECTION 9.5 Maximum Power Transfer Theorem

31. a. Find the value of R for maximum power transfer to R for the network of Fig. 9.133.
- b. Determine the maximum power of R .
32. a. Find the value of R for maximum power transfer to R for the network of Fig. 9.136.
- b. Determine the maximum power of R .
33. a. Find the value of R for maximum power transfer to R for the network of Fig. 9.138.
- b. Determine the maximum power to R .
- *34. a. Find the value of R_L in Fig. 9.142 for maximum power transfer to R_L .
- b. Find the maximum power to R_L .
35. a. For the network of Fig. 9.147, determine the value of R for maximum power to R .
- b. Determine the maximum power to R .
- c. Plot a curve of power to R versus R for R ranging from $1/4$ to 2 times the value determined in part (a) using an increment of $1/4$ the value of R . Does the curve verify the fact that the chosen value of R in part (a) will ensure maximum power transfer?

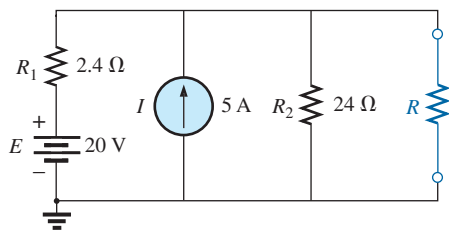

FIG. 9.147
Problem 35.

- *36. Find the resistance R_1 in Fig. 9.148 such that the resistor R_4 will receive maximum power. Think!

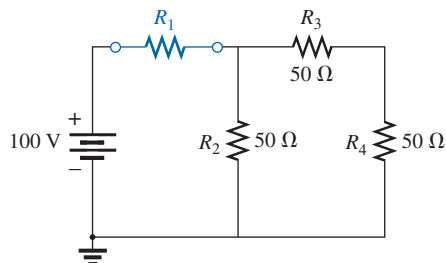

FIG. 9.148
Problem 36.

- *37. a. For the network in Fig. 9.149, determine the value of R_2 for maximum power to R_4 .
- b. Is there a general statement that can be made about situations such as those presented here and in Problem 36?

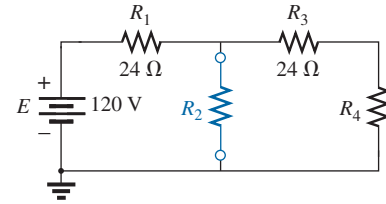

FIG. 9.149
Problem 37.

- *38. For the network in Fig. 9.150, determine the level of R that will ensure maximum power to the $100\ \Omega$ resistor. Find the maximum power to R_L .

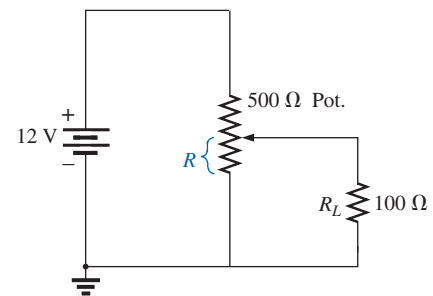

FIG. 9.150
Problem 38.

SECTION 9.6 Millman's Theorem

39. Using Millman's theorem, find the current through and voltage across the resistor R_L in Fig. 9.151.

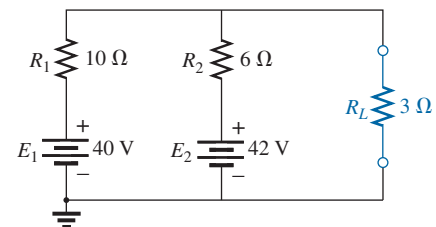

FIG. 9.151
Problem 39.

40. Repeat Problem 38 for the network in Fig. 9.152.

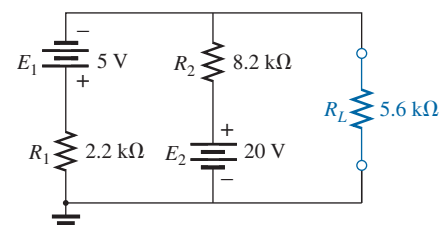

FIG. 9.152
Problem 40.



41. Using Millman's theorem, find the current through and voltage across the resistor R_L in Fig. 9.153.

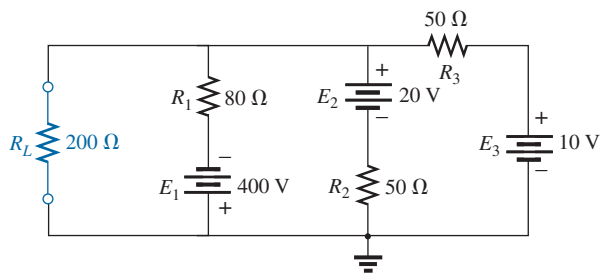

FIG. 9.153

Problem 41.

42. Using the dual of Millman's theorem, find the current through and voltage across the resistor R_L in Fig. 9.154.

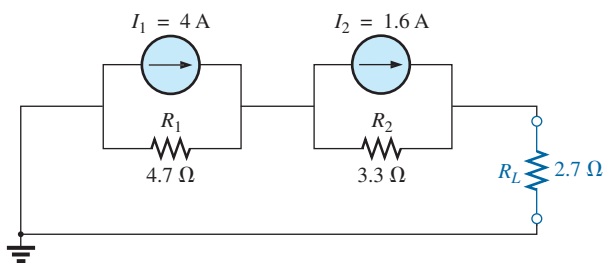

FIG. 9.154

Problem 42.

43. Using the dual of Millman's theorem, find the current through and voltage across the resistor R_L in Fig. 9.155.

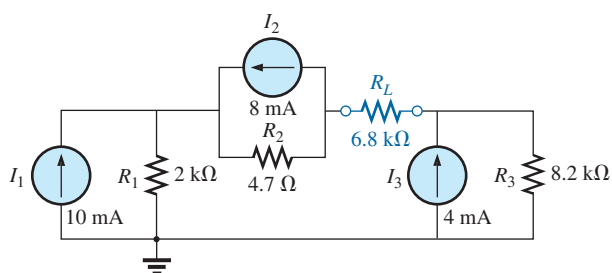

FIG. 9.155

Problem 43.

SECTION 9.7 Substitution Theorem

44. Using the substitution theorem, draw three equivalent branches for the branch $a-b$ of the network in Fig. 9.156.

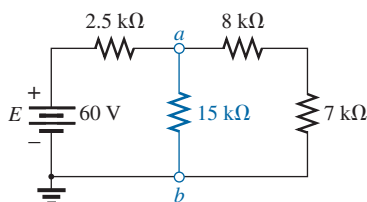

FIG. 9.156

Problem 44.

45. Using the substitution theorem, draw three equivalent branches for the branch $a-b$ of the network in Fig. 9.157.

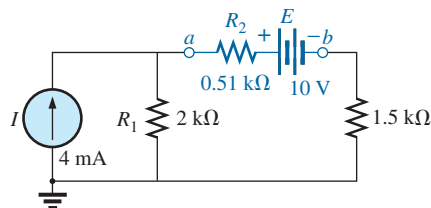

FIG. 9.157

Problem 45.

- *46. Using the substitution theorem, draw three equivalent branches for the branch $a-b$ of the network of Fig. 9.158.

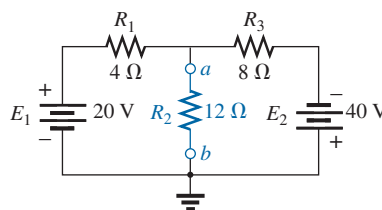
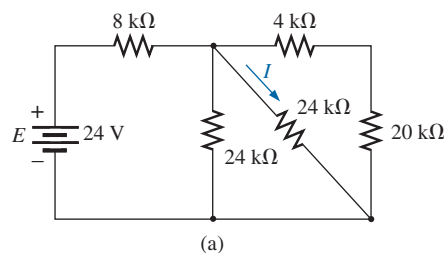

FIG. 9.158

Problem 46.

SECTION 9.8 Reciprocity Theorem

47. a. For the network in Fig. 9.159(a), determine the current I .
 b. Repeat part (a) for the network in Fig. 9.159(b).
 c. Is the reciprocity theorem satisfied?



(a)

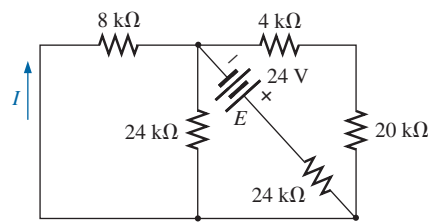

(b)

FIG. 9.159

Problem 47.

48. a. For the network of Fig. 9.160(a), determine the current I .
 b. Repeat part (a) for the network in Fig. 9.160(b).
 c. Is the reciprocity theorem satisfied?

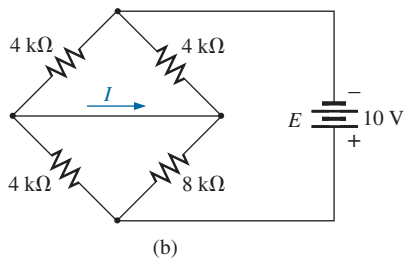
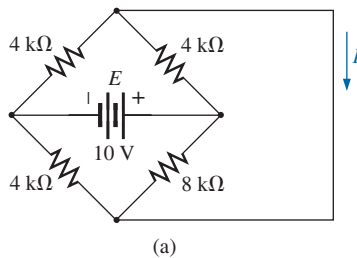

FIG. 9.160
 Problem 48.

49. a. Determine the voltage V for the network in Fig. 9.161(a).
 b. Repeat part (a) for the network in Fig. 9.161(b).
 c. Is the dual of the reciprocity theorem satisfied?

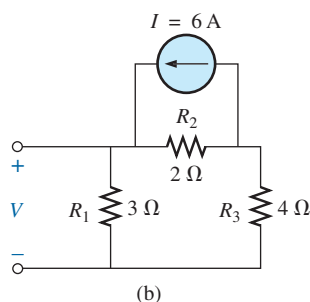
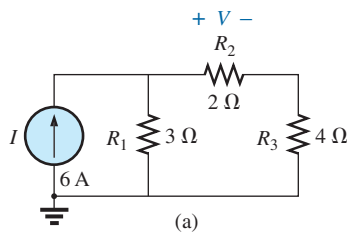

FIG. 9.161
 Problem 49.

SECTION 9.9 Computer Analysis

50. Using PSpice or Multisim and the superposition theorem, determine the voltage V_2 and its components for the network in Fig. 9.130.
51. Using PSpice or Multisim, determine the Thévenin equivalent circuit for the network in Fig. 9.138.
- *52. a. Using PSpice, plot the power delivered to the resistor R in Fig. 9.135 for R having values from $1\ \Omega$ to $10\ \Omega$.
 b. From the plot, determine the value of R resulting in the maximum power to R and the maximum power to R .
 c. Compare the results of part (a) to the numerical solution.
 d. Plot V_R and I_R versus R , and find the value of each under maximum power conditions.
- *53. Change the $300\ \Omega$ resistor in Fig. 9.145 to a variable resistor, and using PSpice, plot the power delivered to the resistor versus values of the resistor. Determine the range of resistance by trial and error rather than first performing a longhand calculation. Determine the Norton equivalent circuit from the results. The Norton current can be determined from the maximum power level.

GLOSSARY

Maximum power transfer theorem A theorem used to determine the load resistance necessary to ensure maximum power transfer to the load.

Millman's theorem A method using source conversions that will permit the determination of unknown variables in a multiloop network.

Norton's theorem A theorem that permits the reduction of any two-terminal linear dc network to one having a single current source and parallel resistor.

Reciprocity theorem A theorem that states that for single-source networks, the current in any branch of a network due to a single voltage source in the network will equal the current through the branch in which the source was originally located if the source is placed in the branch in which the current was originally measured.

Substitution theorem A theorem that states that if the voltage across and current through any branch of a dc bilateral network are known, the branch can be replaced by any combination of elements that will maintain the same voltage across and current through the chosen branch.

Superposition theorem A network theorem that permits considering the effects of each source independently. The resulting current and/or voltage is the algebraic sum of the currents and/or voltages developed by each source independently.

Thévenin's theorem A theorem that permits the reduction of any two-terminal, linear dc network to one having a single voltage source and series resistor.

